

Aircraft Maintenance Manual

Revo

Revision 6.2

March 14, 2025

Evolution Aircraft Inc.

**39440 South Ave
Zephyrhills, FL 33542
USA**

e-mail:

evolutiontrikes@yahoo.com

www.evolutiontrikes.com

Amendments:

Date Of Amendment	Sections Affected	Pages Affected	Date Inserted	Signature
Nov 6, 2010	2.3.5	43-44		
Nov 20, 2012	ALL	ALL		
July 1, 2013	2.3.5	47		
Sept 28, 2015	ALL	ALL		
Nov 20, 2015	ALL	ALL		
January 26, 2016	REV 6.0 ALL	ALL		
April 1, 2022	ALL	ALL	04/01/2022	LM
March 14, 2025	2.3.2.1, 2.3.3.1	27, 32, 36	03/14/2025	LM

AMMENDMENTS NOTE

Manuals can be revised in the future and pages and/or sections re-issued. Amendments will also be available on the distribution website www.evolutiontrikes.com . The amended pages and/or sections should be printed and replaced in the manual at the earliest possible time for safety of flight. The amendment should be logged and recorded in the table above by the owner.

**THIS AIRCRAFT WAS MANUFACTURED IN ACCORDANCE
WITH LIGHT SPORT AIRCRAFT AIRWORTHINESS
STANDARDS F 2317/F 2317M AND DOES NOT CONFORM TO
STANDARD CATEGORY AIRWORTHINESS REQUIRMENTS.**

Copyright Evolution Aircraft, Inc

The data and information contained in the document is the property of Evolution Aircraft Inc. This document may not be reproduced or transmitted to a third party, in any form or by any means. Any unauthorized copy, distribution is illegal as per international agreements relating to property rights.

TABLE OF CONTENTS

EVOLUTION AIRCRAFT INC.....	1
AMENDMENTS:.....	2
AMMENDMENTS NOTE.....	2
1 GENERAL	6
1.1 EQUIPMENT LIST.....	10
1.1.1 Tooling.....	10
1.1.2 Other Possible Required Items	10
1.2 SOURCES TO PURCHASE PARTS	11
1.3 LIST OF DISPOSABLE REPLACEMENT PARTS	11
1.4 ENGINE SPECIFICATIONS	12
1.4.1 Rotax 912 UL.....	12
1.4.2 Rotax 912 ULS.....	13
1.4.3 Rotax 912 iS.....	13
1.5 WEIGHT AND LOADING INFORMATION	14
1.5.1 Center of Gravity Limits	14
1.6 TIRE INFLATION PRESSURES.....	14
1.7 APPROVED OILS AND CAPACITIES	14
1.8 RECOMMENDED FASTENER TORQUE VALUES	15
1.9 GENERAL SAFETY INFORMATION	16
1.9.1 Propeller.....	16
1.9.2 Fuel to Use	17
1.9.3 Dimensions.....	17
1.9.4 Parking, Moving on the Ground and Storage	17
1.9.5 Transporting the Aircraft.....	18
1.9.6 Approved Sources of Information and Maintenance	18
1.9.7 Instructions for Reporting Possible Safety of Flight Concerns.....	19
1.9.8 Placard Replacement.....	19
2 INSPECTIONS	20
2.1 GENERAL	20
2.2 ONE TIME INSPECTIONS	20
2.2.1 Rotax 912UL, 912ULS and 912 iS Motors	20
2.2.1.1 After One (1) Hour.....	20
2.2.1.2 After First Twenty Five (25) Hours.....	22
2.3 ROUTINE PERIODIC INSPECTIONS AND MAINTENANCE	26
2.3.1 Rotax Motors.....	26
2.3.2 Airframe	26
2.3.2.1 Fifty (50) Hour Interval Maintenance and Inspection.....	27
2.3.3 Wing.....	32
2.3.3.1 Fifty (50) Hour Interval Maintenance and Inspection.....	32
2.3.4 Hundred (100) Hour/Annual Inspection (100-h).....	36
2.3.5 Component Replacement Schedule	49
3 STRUCTURES	51
3.1 GENERAL	51
3.2 STRUCTURES.....	51
3.2.1 Wing.....	51
3.2.1.1 Maintenance	51
3.2.1.2 Repair.....	52
3.2.1.3 Alteration.....	54
3.2.2 Carriage.....	55

3.2.2.1 Maintenance	55
3.2.2.2 Repair	55
3.2.2.3 Alterations	76
3.3.3 Engine	76
4 FUEL SYSTEM	77
4.1 GENERAL	77
4.2 MAINTENANCE.....	79
4.3 ALTERATION.....	79
5 PROPELLER.....	79
5.1 GENERAL	79
6 INSTRUMENTS AND AVIONICS	79
7 ELECTRICAL SYSTEM	79
7.1 GENERAL	79
7.2 MAINTENANCE.....	83
7.3 ALTERATION.....	83
8 STRUCTURAL REPAIR	84
9 PAINTING AND COATINGS	84
9.1 GENERAL	84
10 MAJOR REPAIRS AND ALTERATIONS.....	84
10.1 GENERAL	84
11 COMMUNICATION FORMS	85
11.1 OWNER CONTACT INFORMATION	85
11.2 MANDATORY NOTICE QUESTIONS OR COMMENTS	86
11.3 MANDATORY COMPLIANCE WITH NOTICE OF CORRECTIVE ACTIONS	87

1 GENERAL

This manual contains recommended procedures and instructions for ground handling, servicing and maintaining the Revo aircraft. The procedures described are to be used in addition to the particular governing body's regulations for each country where the aircraft is being flown. Where a maintenance procedure contravenes local regulations, the procedures of the local governing body will take precedence.

This manual may refer you to the wing manual(s) for maintenance required for the relevant wing.

This manual may refer you to the engine manual(s) for maintenance required for the relevant engine.

Definitions used in this handbook such as **WARNING**, **CAUTION** and **NOTE** are employed in the following context.

WARNING

Procedures or instructions that if not followed correctly may result in injury or death.

CAUTION

Procedures or instructions that if not followed correctly may result in damage to the aircraft or its parts.

NOTE

Procedures or instructions which are essential to highlight.

Terminology:

- **Annual Condition Inspection** — detailed inspection accomplished once a year on a LSA in accordance with instructions provided in the maintenance manual supplied with the aircraft. The purpose of the inspection is to look for any wear, corrosion, or damage that would cause an aircraft to not be in a condition for safe operation.
- **A&P** — airframe and power plant mechanic as defined by **14 CFR Part 65** in the U.S. or equivalent certification in other countries.
- **FAA** — United States Federal Aviation Administration.
- **Heavy Maintenance** — Maintenance, inspection, repair, or alteration that a manufacturer has designated that requires specialized training, equipment, or facilities.
- **Line Maintenance** — Repair, maintenance, scheduled checks, servicing, inspections, or alterations not considered heavy maintenance that is approved by the manufacturer and is specified in the manufacturer's maintenance manual.
- **LSA (light sport aircraft)** — Aircraft designed in accordance with ASTM standards under the jurisdiction of Committee F37 Light Sport Aircraft, for example, Specification **F 2244** for powered parachutes, Specification **F 2245** for airplanes, and Specification **F 2352** for gyroplanes.
- **LSA Repairman Inspection** — U.S. FAA-certificated repairman (light sport aircraft) with an inspection rating as defined by **14 CFR Part 65**, authorized to perform the annual condition inspection on experimental light sport aircraft, or an equivalent rating issued by other civil aviation authorities. This requires a 16 hour course for Weight Shift Control category aircraft.
- **Discussion** — Experimental LSA do not require the individual performing maintenance to hold any FAA airman certificate in the U.S.
- **LSA Repairman Maintenance** — U.S. FAA-certificated repairman (light sport aircraft) with a maintenance rating as defined by **14 CFR Part 65**, authorized to perform line maintenance on aircraft and the annual condition/100 hour inspection on an LSA, or an equivalent rating issued by other civil aviation authorities.
- **Maintenance Manual(s)** — Manual provided by an LSA manufacturer or supplier that specifies all maintenance, repairs, and alterations authorized by the manufacturer.
- **Major Repair, Alteration, or Maintenance** — Repair, alteration, or maintenance for which instructions to complete the task excluded from the maintenance manual(s) supplied to the consumer are considered major.
- **Manufacturer** — Any entity engaged in the production of an LSA or component used on an LSA.
- **Minor Repair, Alteration, or Maintenance** — Repair, alteration, or maintenance for which instructions provided for in the maintenance manual(s) supplied to the consumer of the product are considered minor.
- **Overhaul** — Maintenance, inspection, repair, or alterations that are only to be accomplished by the original manufacturer or a facility approved by the original manufacturer of the product.
- **Overhaul Facility** — A facility specifically authorized by the aircraft or component manufacturer to overhaul the product originally produced by that manufacturer.
- **Owner/ Operator** — A responsible owner who holds a pilot certificate but who has not received any specific authorized training.

- **Repair Facility** — A facility specifically authorized by the aircraft or component manufacturer to repair the product originally produced by that manufacturer.
- **14 CFR** — Code of Federal Regulations Title 14 Aeronautics and Space also known as the “FARs” or Federal Aviation Regulations.
- **100 Hour Inspection** — Same as an annual condition inspection, except the interval of inspection is 100 hours of operation instead of 12 calendar months. This inspection is utilized when the LSA is being used for commercial operations such as flight instruction, rental or both.

Abbreviations:

AOI — Aircraft Operating Instructions

FTS — Flight Training Supplement

MIP — Maintenance and Inspection Procedures

PIC — Pilot In Command

C — Celsius

F — Fahrenheit

CAS — Calibrated air speed

Hg — Mercury

IAS — Indicated Air Speed

ISA — International Standard Atmosphere

Kg — Kilogram

km/hr — Kilometers per hour

MPH — Miles per hour

kt(s) — Nautical Mile per Hour (knot) (1 nautical mph = (1852/3600) m/s)

lb(s) — Pound(s) (1 lb = 0.4539 kg)

mm — Millimeter

cm — Centimeter

m — Meter

in — Inch

ft — Feet

sq. m — Square Meter

sq. ft — Square Feet

cu. in — Cubic Inches

cm³ — Centimeter Cube

mb — Millibars

N — Newton

Nm — Newton Meter

kW — Kilowatt

HP — Horse Power

RPM — Revolutions Per Minute

ft. lbs — Foot Pounds

in. lbs — Inch Pounds

psi — Pounds per Square Inch gage pressure

s — Seconds

min — Minute(s)

hr(s) — Hour(s)

SI — International System of units

V_A — Maneuvering Speed

V_C — Operating Cruising Speed
 V_{DF} — Demonstrated Flight Diving Speed
 V_H — Maximum Sustainable Speed in straight and level flight
 V_{NE} — Never Exceed Speed
 V_{S0} — Stalling Speed, or the minimum steady flight speed in the landing configuration
 V_{S1} — Stalling Speed, or the minimum steady flight speed in a specific configuration
 V_x — Speed at which Best Angle of Climb is achieved
 V_y — Speed at which Best Rate of Climb is achieved
 V_T — Maximum Glider Towing Speed
 TOSS — Take Off Safety Speed
 W_{susp} — Highest Trike Carriage Weight suspended under the wing
 W_{wing} — Wing Weight
 W_{tkmt} — Trike Carriage Empty Weight (including required minimum equipment, unusable fuel, maximum oil, and where appropriate, engine coolant, hangbolt and hydraulic fluid)
 W_{MAX} — Maximum Design Weight ($W_{wing} + W_{susp}$) WSC — Weight Shift Control (aircraft)
 Max — Maximum
 Min — Minimum

Units:

Speed: Kts (Knots) = 1.15 mph (miles per hour) = 1.84 km/hr
 1 km/hr = 1.6 MPH
 Pressure: PSI = Pounds per Square Inch in
 Hg = inches of Mercury
 mb = millibar
 Distance: in. = inches = 25.4 millimeters
 ft = foot (feet) = .305 meters
 Weights: Kg = kilograms = 2.2 lbs = 2.2 pounds

Miscellaneous:

1 Pound (lb) = 0.4536 Kilogram (kg)
 1 Pound per sq in (psi) = 6.895 Kilopascal (kPa)
 1 Inch (in) = 25.4 Millimeters (mm)
 1 Foot (ft) = 0.3048 Meter (m)
 1 Statute mile = 1.609 Kilometers (km)
 1 Nautical mile (NM) = 1.852 Kilometers (km)
 1 Millibar (mb) = 1 Hectopascal (hPa)
 1 Millibar (mb) = 0.1 Kilopascal (kPa)
 1 Imperial gallon = 4.546 Liters (l)
 1 US gallon = 3.785 Liters (l)
 1 US quart = 0.946 Liter (l)
 1 Cubic foot (ft³) = 28.317 Liters (l)
 1 Degree Fahrenheit (F) = (1.8 X C)+32
 1 Inch Pound (in lb) = 0.113 Newton Meters (Nm)
 1 Foot Pound (ft lb) = 1.356 Newton Meters (Nm)

1.1 Equipment List

1.1.1 Tooling

Tooling required to do maintenance on this aircraft is listed below. Please note that the list may not be comprehensive.

- Loctite (243, 567 and Antisize Lubricant # 76764) For the frame section, ACF-50, WD-40, High-Temp exhaust anti-seize
- The Rotax Maintenance Manual gives a list of consumable materials in section 2.5.
- Torque wrench
- Air Pump
- Various petroleum lubricants
- Automatic Transmission Fluid (ATF) for brakes
- Hydraulic Disc system pressure bleeder tool, available at most auto stores
- Dry Lubricant – lubricant which doesn't attract dust after application.
- WD40 for lubricating the hang block
- UV Resistent Tie wraps, and tooling
- Stainless Steel aircraft Cable and Swages and tooling
- SAE Hex key set
- Gasoline resistant thread sealant tape
- Various general care items
- Metric and SAE Socket Wrench Set
- Pliers and Vise Grips
- Phillips and Regular Screw Driver Set
- A hoist pulley system
- Flexible neck funnel
- Bettsometer (sail strength)
- Inspection telescopic extension mirrors
- Telescopic extension strong magnet

1.1.2 Other Possible Required Items

- Safety Rings
- Safety Pins
- ACF-50, CRC or another water displacement compound
- K&N air filter cleaning spray and oil
- Flashlight
- 5X-10X magnifying glass

1.2 Sources to Purchase Parts

Parts can be purchased from the following sources:

Component	Source
Carriage Frame Items	<ul style="list-style-type: none"> Evolution Aircraft, Inc
Carriage Hardware, Tires	<ul style="list-style-type: none"> Evolution Aircraft, Inc AN hardware of the correct size from reputable aircraft supply houses McCreary Air Trac aircraft tires 7.00 x 6.00 (6-Ply) from aircraft supply house
Wing Components and Hardware	<ul style="list-style-type: none"> Evolution Aircraft, Inc AN hardware of correct size from reputable aircraft supply houses
Propeller Parts	<ul style="list-style-type: none"> Sensenich Propeller Warp Drive Propeller
Aero-tuff	<ul style="list-style-type: none"> Seatbelts

1.3 List of Disposable Replacement Parts

Dispose of all disposable parts properly following local laws and regulations.

Part	Comments
Fuel Filters	Evolution Aircraft supplied Gascolator filter 912iS equipped Bosch EAFF0-127 fine filter
Air Filters	K&N air filters are used. They can be cleaned following K&N air filter cleaning guidelines but if appropriate, they can also be replaced with new ones and old ones disposed
Tires	McCreary Air Trac aircraft tires 7.00 x 6.00 (6-Ply) and should be disposed properly according to local laws
Oil Filters	Oil filters should be properly disposed along with the oil at each oil change
Fuel sight gauge clear line	Tygothane fuel line replacement
Fuel Line	When fuel line has to be replaced, the old one should be properly disposed

Part	Comments
Battery	When the sealed maintenance free battery is to be replaced, the older battery should be properly recycled according to local laws

1.4 Engine Specifications

Revo is available with the following ASTM complaint engines:

1.4.1 Rotax 912 UL



Version		Performance			Torque			Max RPM
		kW	HP	RPM	Nm	ft. lb.	RPM	RPM
912 UL2		58.0	79	5500	103	75.9	4800	5800
Max 5 min (take-off)		59.6	81	5800				
Bore		Stroke		Displacement			Compression Ratio	
79.5 mm	3.13 in.	61 mm	2.4 in.	1211.2 cm ³	73.91 cu. in.	9.0:1		

1.4.2 Rotax 912 ULS



Version		Performance			Torque			Max RPM
		kW	HP	RPM	Nm	ft. lb.	RPM	RPM
912 ULS2		69.0	95	5500	128	94	5100	5800
Max 5 min (take-off)		73.5*	100*	5800*	* with Rotax airbox & exhaust system			
Bore		Stroke		Displacement		Compression Ratio		
84 mm	3.31 in.	61 mm	2.4 in.	1352 cm ³	82.6 cu. in.	10.5:1		

1.4.3 Rotax 912 iS



Version		Performance			Torque			Max RPM
		kW	HP	RPM	Nm	ft. lb.	RPM	RPM
912 IS		69.0	92	5500	121	89	5800	5800
Max 5 min (take-off)		73.5*	100*	5800*	* with Rotax airbox & exhaust system			
Bore		Stroke		Displacement		Compression Ratio		
84 mm	3.31 in.	61 mm	2.4 in.	1352 cm ³	82.6 cu. in.	10.8:1		

1.5 Weight and Loading Information

Center of gravity limits are not critical in a flex-wing weight shift control aircraft. The carriage attaches to the wing through a universal junction known as hang block assembly. Variations in cockpit and fuel loading cannot affect aircraft's balance significantly. The aircraft is therefore not critical in terms of center of gravity. However, distribution of load in a trike carriage affects the attitude of the trike carriage in-flight in a minor way and the hang block position on the wing's keel effects the wings CG.

Please refer to weight and loading document for airworthiness.

1.5.1 Center of Gravity Limits

Base Suspension Range (Measured from the front of the keel tube attached to the wing keel to the suspension point on the hang block)	Dimension (Metric)	Dimension (Imperial/US)
Reflex Competition 11	1320.8 mm - 1422.4 mm	52" -56"
RIVAL (Discontinued)	1422.4 mm - 1498.6 mm	50" - 54"
RIVAL S	1422.4 mm - 1498.6 mm	50" - 54"
Reflex Sport 12.5 (Discontinued)	1295.4 mm - 1447.8 mm	51" -57"
Reflex Discovery 13.5	1346.2 mm - 1498.6 mm	53"- 59"

1.6 Tire Inflation Pressures

McCreary Air Trac 7.00 x 6.00 aircraft tires should be inflated to between 18 and 35 psi for both front and back tires.

1.7 Approved Oils and Capacities

Please refer to Rotax engine manual for oil recommendations.

1.8 Recommended Fastener Torque Values

Fastener	Metric	Imperial
Hang Bolt and Folding Mast Bolt	Hand tight ONLY with safety pin or ring	Hand tight ONLY with safety pin or ring
Axle Bolts	Snug tight with a wrench then back off so the cotter pin can be inserted for safety (if applicable). If needed appropriate washers can be added	Snug tight with a wrench then back off so the cotter pin can be inserted for safety (if applicable). If needed appropriate washers can be added
Other Carriage Bolts and Nylock Nuts*	AN-4 (1/4-inch) bolts – 17 NM	AN-4 (1/4-inch) bolts – 156 inch-pounds
	AN-5 (5/16-inch) bolts – 22 NM	AN-5 (5/16-inch) bolts – 195 inch-pounds
	AN-6 (3/8-inch) bolts – 34 NM	AN-6 (3/8-inch) bolts – 300 inch-pounds
Propeller	Refer to the propeller Manual	Refer to the propeller manual
Wing Fasteners	Refer to the wing manual. If values are found in wing manual they override these recommendations. If using Nylocks, they should not be torqued down but just kept snug tight with one to three threads showing. We do not recommend torqueing any bolts that go through tubing or fittings.	Refer to the wing manual. If values are found in wing manual they override these recommendations. If using Nylocks, they should not be torqued down but just kept snug tight with one to three threads showing. We do not recommend torqueing any bolts that go through tubing or fittings
Engine Hardware	Please refer to engine manual	Please refer to engine manual

* In preparing this guide to torque values, the following basic assumptions have been made:

- Bolts and nuts are new, standard finish AN hardware and dry threads. Lubricated threads will require lower torque values by about 20%. For older nuts and bolts 10% to 20% lower torque specification should be used.
- The load will be 90% of the bolt yield strength.
- The coefficient of friction (μ) is 0.14
- The final tightening sequence is achieved smoothly and slowly, until the torque tool indicates full torque has been obtained.

1.9 General Safety Information

Qualifications for the person doing the maintenance vary from country to country. The operator/mechanic should be familiar with the local requirements. Maintenance requirements are outlined in the maintenance manual for the base unit and in the engine manuals for the engine.

NOTE

To protect hardware from elements it is highly recommended that a water displacement compound like ACF-50 be sprayed from time to time to prevent galvanic corrosion. This can be done by the owner. Excess should be wiped off immediately after spraying. Alternately compounds like Pennzoil Marine sprays after replacement of hardware can be used as they make a waxy film around the metal and protect it from the elements for up to 6 months or as advertised. Treating the engine with water displacement compounds makes it easier to clean and maintain the engine's appearance. Excess should be wiped off with a soft cloth.

NOTE

It is very important that FOD (Foreign Object Debris) be kept clearly out of the aircraft. We recommend not setting any tools or fasteners inside or on the aircraft and instead using a project tray outside with all tools and fasteners/parts required. Items such as the gas cap, tools and other objects should **NEVER** be placed on the seats, floor board or top of the engine where they can fly out during taxi or flight if forgotten.

It is also important to pay particular attention to chafing of lines and wires. Battery terminals should be disconnected while work is being performed. It is easy to drop fasteners into the body cavity of these aircraft unless conscious effort is made not to do so. A strong magnet pickup and a bright flashlight are good to have in such circumstances. Do **NOT** leave small objects such as nuts or bolts in the body which can escape during flight creating falling debris or impact the pusher propeller.

1.9.1 Propeller

The propeller should be checked for pitch consistency between the blades (< 0.3 degrees) and the bolts should be checked for torque the first 25 hours with an accurate torque wrench to propeller manufacturer values. Refer to the propeller manual for more details on maintaining the propeller.

1.9.2 Fuel to Use

The following fuels are preferred to be used on the aircraft:

- 912 UL: Lead Free 89 Octane US or higher
- 912 ULS and 912 iS: Lead Free 91 US Octane or higher
- 912 UL, 912 ULS, 912 iS: Avgas 100LL

NOTE

Due to higher lead content in AVGAS, the wear of the valve seats and deposits in the combustion chamber will increase. Use of Avgas requires more frequent oil changes and requires use of non-synthetic oil only.

NOTE

Please refer to the Rotax engine manuals for further information on fuel and oil to use with their engine.

1.9.3 Dimensions

Please refer to the Aircraft Operating Instructions (AOI) for this information.

1.9.4 Parking, Moving on the Ground and Storage

Make sure area is clear, ignition is off and if applicable BRS safety pin is in before moving the aircraft on the ground manually.

While moving the aircraft take care to not put weight or excessive pressure on the front fairing wheel pants or engine cowlings. Before moving the aircraft secure the wing's A-frame and move carefully negotiating the wind direction with the wing's position.

Pulling the trike: Moving the base (with or without the wing) is facilitated by lifting the front wheel and walking the base. Do not pull excessively hard on the compression strut or nose strut of the aircraft carriage. If a hard pull is needed, it's best to push the aircraft from the prop hub (back). Steer the trike while manually moving by pushing the nose wheel or front steering in the desired direction. Alternately the front wheel can be placed on a castering support and steered freely.

Pushing the trike: The trike can be pushed using pushing on the prop hub on even surface. Steering is slower and harder using this method except when using castering support on the front wheel

Parking: Parking the aircraft requires using chocks, applying parking brake (refer to AOI) and securing the wing with the upwind wing down. In higher or gusty wind conditions, the wing should be tied down or if appropriate taken down or the trike should be moved indoors. Alternately the trike may be faced into the wind with the control bar back resting on the front of the pilot seat back with the rear seat belt looping around the control bar pulling it back tight against the pilot seat back.

Please refer to Section 4 of the Aircraft Operating Instructions (AOI) for further information.

NOTE

The trike carriage or base can be moved with or without the wing.

Long term Storage: Long term storage will require the supplied air filter(s) and exhaust be covered to prevent foreign objects getting in the air intake and exhaust area. Full covers for the carriage and prop blades are advisable, which are available as aftermarket items from the manufacturer. The engine manual should be consulted for long-term storage practices for the engine. Generally emptying the carb bowls, fuel tank and using fogging oil inside the engine is recommended to keep engine free of rust etc. Consult the AOI, section 4, for further information regarding long-term storage.

NOTE

Do not store the trike outside for any appreciable length of time where it is exposed to the elements. This may reduce life of the sail and other items severely.

1.9.5 Transporting the Aircraft

Refer to the Aircraft Operating Instructions (AOI).

1.9.6 Approved Sources of Information and Maintenance

The following are the approved sources for further information regarding maintenance:

- Evolution Aircraft, Inc (<http://www.evolutiontrikes.com/>)
- MGL Avionics. South Africa (<http://www.mglavionics.co.za/>) (Stratomaster Instrumentation)
- Aero-Tuff USA (<http://www.aero-tuff.com>) (Seatbelts)
- Rotax Austria and its authorized representatives (Rotax Engines)

1.9.7 Instructions for Reporting Possible Safety of Flight Concerns

If you discover any problems during maintenance of this aircraft that in your opinion can cause safety of flight issues, please report that concern to Evolution Aircraft, Inc in the following way:

- 1) Use the attached form in this manual or compose an e-mail to:

support@Evolutiontrikes.com with subject:

“Safety of Flight Issue – Evolution Trikes, REVO – Serial#_____

- 2) In the body of the message please follow this format:

Model: Evolution Aircraft Inc. REVO
Serial Number: xxxxxx
Number of Hours: Enter number of flight hours on aircraft.
Wing: Name the wing model you have on the trike carriage.
Part/Area: Example, Mast/Pylon, Trike Base tube, Wing Keel etc.
Description: Please describe the issue as best as you can Images/Pictures
Please attach digital format pictures of the problem area(s)
Suggested Remedy: Enter any suggested remedy if you have one

Name: Enter your full name here
Title: Enter your title here (owner/mechanic/inspector)
Qualification: 16-hour class, 110-hour class, A&P mechanic etc.
Address: Enter your address here
Phone(s): Enter phone number(s) we can contact you at
e-mail: Enter your e-mail address if applicable

Or download our form at: <http://www.evolutiontrikes.com/bulletins-manuals.htm>

Please note that if the concern is related to the engine internals, we may refer you to a certified engine service station.

1.9.8 Placard Replacement

If placards need to be replaced you can order them through the factory.

2 INSPECTIONS

2.1 General

This section covers instructions and checklists for the completion of periodic and annual condition/100 hour inspections, as appropriate.

2.2 One Time Inspections

2.2.1 Rotax 912UL, 912ULS and 912 iS Motors

Run-in: The initial engine run-in of Rotax 912UL/ULS/iS was carried out by the Rotax factory. The purging of the oil circuit, carburetor balancing, if applicable, was carried out by Evolution Aircraft Inc. prior to delivery. During the first two (2) hours of use, we advise you to fly only solo, only use maximum power on takeoffs if necessary, and avoid prolonged use at maximum power. Also, consult the engine manual. The propeller blades have been adjusted at the factory to not exceed 5650 RPM on the ground. Use the propeller manufacturer recommended procedure for any modification to the propeller pitch.

2.2.1.1 After One (1) Hour

NOTE

If unsure about how to do a certain task we recommend that you refer to the factory for clarification. Generally this inspection will be done at the factory if the trike is a Special Light Sport after test flights. In this case it is not necessary for the owner to do these inspections.

Pre-Requisites:

1. Take engine cover, if applicable, and rear cowling section off the aircraft.
2. Tools and materials necessary to perform this inspection are listed in section 1.1 of this manual.

Type	Action	Description	Personnel Authorized
Line Maintenance	Re-torque the Exhaust manifold bolts	Re-torque the exhaust manifold bolts to engine manufacturer's specifications.	<ul style="list-style-type: none"> • Owner (holds at least a sport pilot certificate) • LSA Repairman Inspection (only if ELSA) • LSA Repairman Maintenance • A&P • Repair Station

Line Maintenance	Check wheel pants for looseness. ONLY If the wheel pant is loose, remove loose bolts and apply 242 blue locktight and re-tighten	Check to make sure wheel pants are tight.	<ul style="list-style-type: none"> • Owner (holds at least a sport pilot certificate) • LSA Repairman Inspection (only if ELSA) • LSA Repairman Maintenance • A&P • Repair Station
Line Maintenance	Tighten hose clamps on radiator	Check for any coolant leaks at inlet and exit of radiator.	<ul style="list-style-type: none"> • Owner (holds at least a sport pilot certificate) • LSA Repairman Inspection (only if ELSA) • LSA Repairman Maintenance • A&P • Repair Station
Line Maintenance	Add air to the tires to keep them within 18-35 PSI.	Check air pressure in tires.	<ul style="list-style-type: none"> • Owner (holds at least a sport pilot certificate) • LSA Repairman Inspection (only if ELSA) • LSA Repairman Maintenance • A&P • Repair Station
Line Maintenance	Re-torque the propeller bolts and check the state of the propeller	Re-torque the propeller bolts and check the state of the propeller. For procedure please look at the propeller manual.	<ul style="list-style-type: none"> • Owner (holds at least a sport pilot certificate) • LSA Repairman Inspection (only if ELSA) • LSA Repairman Maintenance • A&P • Repair Station
Line Maintenance	Lubricate hardware on the wing.	Use a spray lubricant and a water displacement compound on the joints and hardware of the wing. Wipe away excess immediately with a soft cloth.	<ul style="list-style-type: none"> • Owner (holds at least a sport pilot certificate) • LSA Repairman Inspection (only if ELSA) • LSA Repairman Maintenance • A&P • Repair Station

2.2.1.2 After First Twenty Five (25) Hours

Pre-Requisites:

3. Take engine cover, if applicable, and rear cowling section off the aircraft.
4. Take the seat pan out.
5. Tools and materials necessary to perform this inspection are listed in section 1.1 of this manual.
6. If unsure about how to do a certain task we recommend that you get clarification first.

Type	Action	Description	Personnel Authorized
Line Maintenance	Change Oil if applicable	Refer to engine manual. NOTE On 912UL, 912ULS and 912iS motors there is a drain plug in the oil reservoir at the bottom (refer to Rotax information). 2014 models and later are plumbed with a Curtis Quick drain. The oil reservoir can be completely removed from the trike frame by unfastening the band holding it to the frame. No oil lines need to be disconnected.	<ul style="list-style-type: none"> • Owner (holds at least a sport pilot certificate) • LSA Repairman Inspection (only if ELSA) • LSA Repairman Maintenance • A&P • Repair Station
Line Maintenance	Check wheel pants for looseness. ONLY If the wheel pant is loose, remove loose bolts and apply 242 blue locktight and re-tighten	Check to make sure wheel pants are tight.	<ul style="list-style-type: none"> • Owner (holds at least a sport pilot certificate) • LSA Repairman Inspection (only if ELSA) • LSA Repairman Maintenance • A&P • Repair Station

Type	Action	Description	Personnel Authorized
Line Maintenance	Check oil filter for metal deposits.	Open the oil filter and check for the presence of metal deposits.	<ul style="list-style-type: none"> • Owner (holds at least a sport pilot certificate) • LSA Repairman Inspection (only if ELSA) • LSA Repairman Maintenance • A&P • Repair Station
Line Maintenance	Tighten hose clamps on radiator	Check for any coolant leaks at inlet and exit of radiator	<ul style="list-style-type: none"> • Owner (holds at least a sport pilot certificate) • LSA Repairman Inspection (only if ELSA) • LSA Repairman Maintenance • A&P • Repair Station
Line Maintenance	Add air to the tires to keep them within 18-35 PSI.	Check air pressure in tires	<ul style="list-style-type: none"> • Owner (holds at least a sport pilot certificate) • LSA Repairman Inspection (only if ELSA) • LSA Repairman Maintenance • A&P • Repair Station
Line Maintenance	Magnetic Pickup in gearbox cleaned	Clean the magnetic 'pick-up' bolt in the gearbox housing.	<ul style="list-style-type: none"> • Owner (holds at least a sport pilot certificate) • LSA Repairman Inspection (only if ELSA) • LSA Repairman Maintenance • A&P • Repair Station

Type	Action	Description	Personnel Authorized
Line Maintenance	Oil Hose and connections	Check the state of the oil hoses and the tightness of the oil connections.	<ul style="list-style-type: none"> • Owner (holds at least a sport pilot certificate) • LSA Repairman Inspection (only if ELSA) • LSA Repairman Maintenance • A&P • Repair Station
Line Maintenance	Carburetors, carburetor supports and air filters secure, if applicable.	Check that the carburetors, carburetor supports and air filters are secure.	<ul style="list-style-type: none"> • Owner (holds at least a sport pilot certificate) • LSA Repairman Inspection (only if ELSA) • LSA Repairman Maintenance • A&P • Repair Station
Line Maintenance	Throttle cable tension	Check the tension and stops of the throttle cables	<ul style="list-style-type: none"> • Owner (holds at least a sport pilot certificate) • LSA Repairman Inspection (only if ELSA) • LSA Repairman Maintenance • A&P • Repair Station
Line Maintenance	Idle RPM	Check Idle RPM. 1550-1950	<ul style="list-style-type: none"> • Owner (holds at least a sport pilot certificate) • LSA Repairman Inspection (only if ELSA) • LSA Repairman Maintenance • A&P • Repair Station
Line Maintenance	Color and State of Spark Plugs	Check the state and the color of the spark plugs (for a correct air/fuel mixture). Replace if necessary. Consult engine manual for spark plug gap and torque.	<ul style="list-style-type: none"> • Owner (holds at least a sport pilot certificate) • LSA Repairman Inspection (only if ELSA) • LSA Repairman Maintenance • A&P • Repair Station

Type	Action	Description	Personnel Authorized
Line Maintenance	Bolts, nuts, safety pins	Check that no bolt, nut or safety pin is missing or loose or rusting.	<ul style="list-style-type: none"> • Owner (holds at least a sport pilot certificate) • LSA Repairman Inspection (only if ELSA) • LSA Repairman Maintenance • A&P • Repair Station
Line Maintenance	Fuel System	Check the fuel system, hose connections, gascolator drain line, filter, pump (leaks – abnormal wear). Replace if necessary	<ul style="list-style-type: none"> • Owner (holds at least a sport pilot certificate) • LSA Repairman Inspection (only if ELSA) • LSA Repairman Maintenance • A&P • Repair Station
Line Maintenance	Electric Wire Harness	Check the electric wire harness for abnormal wear or chafing.	<ul style="list-style-type: none"> • Owner (holds at least a sport pilot certificate) • LSA Repairman Inspection (only if ELSA) • LSA Repairman Maintenance • A&P • Repair Station
Line Maintenance	Liquid Coolant Level	Check the level of the liquid coolant in the radiator reservoir (above the minimum mark – do not overfill).	<ul style="list-style-type: none"> • Owner (holds at least a sport pilot certificate) • LSA Repairman Inspection (only if ELSA) • LSA Repairman Maintenance • A&P • Repair Station
Line Maintenance	Brake Condition	Check the ATF for the brake system. Check lines and fittings for leaks.	<ul style="list-style-type: none"> • Owner (holds at least a sport pilot certificate) • LSA Repairman Inspection (only if ELSA) • LSA Repairman Maintenance • A&P • Repair Station

NOTE:

On the Revo, the oil reservoir is accessed by taking off the rear lower grill cover attached with quarter turn fasteners. Furthermore, the lower back fairing can be completely removed as well for additional working area. The oil reservoir is attached at an angle to a bracket with a metal band clamp which can be released by loosening and sliding down to take the reservoir out and change oil per Rotax instructions. Please note the lip of the upper reservoir must rest on top of the frame bracket and “latch on” before reinstalling the band clamp.

If you have never done a Rotax 912 series oil change before, it is highly recommended that you follow Rotax engine oil change guidance. Rotax has provided video instruction of the proper way of doing oil change and oil purging and carb synching at <http://www.rotax-owner.com> mouse over “Support” and select “Expanded Video Instructions” to see the e-training videos before doing these regular maintenance items. These videos may require you to become a member and pay a fee.

2.3 Routine Periodic Inspections and Maintenance

2.3.1 Rotax Motors

Consult the engine manuals, Technical bulletins and Service Information for getting the intervals to do routine maintenance on your engine.

NOTE

More information and Rotax instructions available at Internet site: <http://www.rotax-aircraft-engines.com>

2.3.2 Airframe

NOTE

If unsure about how to do a certain task we recommend that you refer to FAA AC 43.13-1B for details.

By consistently carrying out an effective **PREFLIGHT** this should uncover any possible irregularities. For that reason attention should be drawn to the AOI section 4 to the preflight checklists. The maintenance of the aircraft should be carried out adhering to the component replacement cycle of each sub-component (Section X of this manual).

2.3.2.1 Initial Fifty (50) Hour Maintenance and Inspection

Pre-Requisites:

1. Remove the engine cowling (if applicable) and rear section cowling.
2. Remove the seat pan
3. Tools and materials necessary to perform this inspection are listed in section 1.1 of this manual.

Type	Action	Description	Personnel Authorized
Line Maintenance	Apply ACF-50	Apply to hardware, can be used on electrical connections. Spray inside of steel tubing. Excess wiped off with a soft cloth immediately after spraying. Can be used to lubricate any rotating free joint like front fork etc.	<ul style="list-style-type: none"> • Owner (holds at least a sport pilot certificate) • LSA Repairman Inspection (only if ELSA) • LSA Repairman Maintenance • A&P • Repair Station
Line Maintenance	Apply ACF-50	Apply to folding mast joint area	<ul style="list-style-type: none"> • Owner (holds at least a sport pilot certificate) • LSA Repairman Inspection (only if ELSA) • LSA Repairman Maintenance • A&P • Repair Station
Line Maintenance	Check all bolts, nuts, safety wires and lock pins for condition and rust	Safety wires if broken or rusted should be replaced. Lock pins should be in good condition and not bent or rusted. Replace if necessary.	<ul style="list-style-type: none"> • Owner (holds at least a sport pilot certificate) • LSA Repairman Inspection (only if ELSA) • LSA Repairman Maintenance • A&P • Repair Station <p>WARNING: Please follow proper procedure for safety wiring the propeller and exhaust springs. If in doubt refer to FAA Advisory Circular AC 43.13-1B</p>

Type	Action	Description	Personnel Authorized
Line Maintenance	Change Oil if applicable (courtesy reminder only)	Refer to engine manual	<ul style="list-style-type: none"> • Owner (holds at least a sport pilot certificate) • LSA Repairman Inspection (only if ELSA) • LSA Repairman Maintenance • A&P • Repair Station
Line Maintenance	Check Coolant level in reservoir (courtesy reminder only)	Add coolant if necessary. We recommend 50/50 Dexcool coolant. If water is used to make a 50/50 mix, it should always be distilled water only.	<ul style="list-style-type: none"> • Owner (holds at least a sport pilot certificate) • LSA Repairman Inspection (only if ELSA) • LSA Repairman Maintenance • A&P • Repair Station
Line Maintenance	Check all hoses, clamps for leaks	Check all hoses including oil, fuel and coolant lines for condition and leaks. Replace and/or tighten as necessary. Hose clamps should be snug but not overly tight. A force of 18 inch pounds (2 NM) is generally sufficient to make a good seal. Hoses replaced should be appropriate size and applicable to task. Fuel lines should be auto fuel lines resistant to alcohol/ethanol.	<ul style="list-style-type: none"> • Owner (holds at least a sport pilot certificate) • LSA Repairman Inspection (only if ELSA) • LSA Repairman Maintenance • A&P • Repair Station
Line Maintenance	Check fuel filter/gascolator and fuel flow sensor if applicable	Check visually for contamination and replace or clean if necessary	<ul style="list-style-type: none"> • Owner (holds at least a sport pilot certificate) • LSA Repairman Inspection (only if ELSA) • LSA Repairman Maintenance • A&P • Repair Station

Type	Action	Description	Personnel Authorized
Line Maintenance	Check Air Filter and clean if necessary	Check K&N air filter and if necessary clean using cleaning spray and oil for K&N air filters. Follow directions of cleaning bottles.	<ul style="list-style-type: none"> • Owner (holds at least a sport pilot certificate) • LSA Repairman Inspection (only if ELSA) • LSA Repairman Maintenance • A&P • Repair Station
Line Maintenance	Check Wiring behind the instrument panel for possible chafing	Look under and behind the instrument panel with a flash light to see any chafing or irregularities.	<ul style="list-style-type: none"> • Owner (holds at least a sport pilot certificate) • LSA Repairman Inspection (only if ELSA) • LSA Repairman Maintenance • A&P • Repair Station
Line Maintenance	Propeller checked and re-torqued	Blades and hub bolts torque checked. Look for any cracks in the hub and de-lamination of propeller blades Clean propeller with mild detergent, water and sponge. Use wax protect finish.	<ul style="list-style-type: none"> • Owner (holds at least a sport pilot certificate) • LSA Repairman Inspection (only if ELSA) • LSA Repairman Maintenance • A&P • Repair Station
Line Maintenance	Throttle and choke cables and stops	Check operation of throttle and choke for smoothness. Cable has been oiled at factory but if necessary re-oil with light machine oil. Stops should be secured.	<ul style="list-style-type: none"> • Owner (holds at least a sport pilot certificate) • LSA Repairman Inspection (only if ELSA) • LSA Repairman Maintenance • A&P • Repair Station <p style="text-align: center;">WARNING</p> <p>If unsure of how to do this please refer this to a qualified mechanic.</p>

Type	Action	Description	Personnel Authorized
Line Maintenance	Battery condition	Check battery voltage and condition. If below 12 volts, recharge. Voltage can be easily checked by turning on the glass cockpit without the engine running and noting the voltage. If the battery terminals need cleaning, clean them and apply di-electric grease or battery terminal protectant spray.	<ul style="list-style-type: none"> • Owner (holds at least a sport pilot certificate) • LSA Repairman Inspection (only if ELSA) • LSA Repairman Maintenance • A&P • Repair Station
Line Maintenance	Wiring Harness	Check wiring connections visually for obvious defects and arrange correction with a qualified person if necessary.	<ul style="list-style-type: none"> • Owner (holds at least a sport pilot certificate) • LSA Repairman Inspection (only if ELSA) • LSA Repairman Maintenance • A&P • Repair Station
Line Maintenance	Seatbelt condition	Check seatbelts for cuts and nicks. If any found replace.	<ul style="list-style-type: none"> • Owner (holds at least a sport pilot certificate) • LSA Repairman Inspection (only if ELSA) • LSA Repairman Maintenance • A&P • Repair Station
Line Maintenance	Hang bolt condition	Check. Replace based on condition if necessary or every 400 hours.	<ul style="list-style-type: none"> • Owner (holds at least a sport pilot certificate) • LSA Repairman Inspection (only if ELSA) • LSA Repairman Maintenance • A&P • Repair Station

Type	Action	Description	Personnel Authorized
Line Maintenance	Tire Tread	Check tires for irregular wear	<ul style="list-style-type: none"> • Owner • LSA Repairman Inspection (only if ELSA) • LSA Repairman Maintenance • A&P • Repair Station
Line Maintenance	Idle RPM	Check Idle RPM. Consult engine manual	<ul style="list-style-type: none"> • Owner (holds at least a sport pilot certificate) • LSA Repairman Inspection (only if ELSA) • LSA Repairman Maintenance • A&P • Repair Station
Line Maintenance	Carburetors, carburetor supports and air filters secure. Sync carbs per Rotax instructions if applicable	Check that the carburetors, carburetor supports and air filters are secure. Sync carbs per Rotax instructions NOTE: Make sure that the choke is completely OFF before syncing carbs and warm up the engine before making adjustments.	<ul style="list-style-type: none"> • Owner (holds at least a sport pilot certificate) • LSA Repairman Inspection (only if ELSA) • LSA Repairman Maintenance • A&P • Repair Station
Line Maintenance	Clean the carriage	Follow the cleaning procedures in the AOI to clean the trike carriage. Use good quality wax to protect after cleaning.	<ul style="list-style-type: none"> • Owner (holds at least a sport pilot certificate) • LSA Repairman Inspection (only if ELSA) • LSA Repairman Maintenance • A&P • Repair Station

2.3.3 Wing

NOTE

If unsure about how to do a certain task we recommend that you refer to FAA AC 43.13-1B for details.

2.3.3.1 Initial Fifty (50) Hour Maintenance and Inspection

Pre-Requisites:

1. Tools and materials necessary to perform this inspection are listed in section 1.1 of this manual.
2. Use magnifying glass where appropriate when checking sail and cabling and tubing.
3. It is not necessary to de-rig the wing to perform this inspection.

Type	Action	Description	Personnel Authorized
Line Maintenance	Check Hardware	Check all fasteners (bolts, screws, rollers, nuts, splint pins etc.) for corrosion or rust. Any corroded fasteners should be replaced. Bolts should not be worn and/or bent. Key bolts should be checked most thoroughly for cracks between the head and the bolt body. These are the bolts at the control bar side and bottom joints, the central spreader bar tensioning cable attach point and the rear cable attachment point on the keel tube. If any cracks are observed – REPLACE IMMEDIATELY!	<ul style="list-style-type: none"> • Owner (holds at least a sport pilot certificate) • LSA Repairman Inspection (only if ELSA) • LSA Repairman Maintenance • A&P • Repair Station

Type	Action	Description	Personnel Authorized
Line Maintenance	Apply ACF-50 or like compound	Apply to hardware and joints. Excess wiped off with a soft cloth immediately after spraying. Can be used to lubricate.	<ul style="list-style-type: none"> • Owner (holds at least a sport pilot certificate) • LSA Repairman Inspection (only if ELSA) • LSA Repairman Maintenance • A&P • Repair Station
Line Maintenance	Checking the sail surface and seams	<p>There should be no cuts, ruptures, threadbare holes and torn seams on the sail. Any torn seams should be re-stitched. Cuts and ruptures on the under surface of the sail that are not longer than 30 mm can be patched with self-adhesive Dacron/Mylar. The Dacron/ Mylar must be of a weight of not less than 100 g/m. Larger cuts and ruptures are to be repaired by stitching on a reinforcing piece of the same fabric (stitched along the edges). Any rupture shorter than 8” can be repaired in this manner, but more complicated repairs and all cuts near the trailing edge upper surface should be carried out in the workshop of producing company. If any of the batten tightening cords are torn or heavily worn they must be replaced.</p> <p>NOTE-Keep an eye on the sail grommets and all areas of the sail that are subject to extra stress, especially the keel section, the nose section of the leading edge and outer tip section of the leading edge.</p>	<ul style="list-style-type: none"> • Owner (holds at least a sport pilot certificate) • LSA Repairman Inspection (only if ELSA) • LSA Repairman Maintenance • A&P • Repair Station <p style="text-align: center;">WARNING</p> <p>The inspection can be done by the above personnel but any stitching or large cuts or trailing edge nicks and cuts should be fixed by personnel authorized by the wing or trike manufacturer ONLY! That have specialty knowledge of trike or hang glider wing sail repair.</p>

Type	Action	Description	Personnel Authorized
Line Maintenance	Check Cabling	<p>The cables must be checked for broken wires and corrosion. If any defect on a wire is observed, no matter how small, the cable in question MUST BE REPLACED. It is recommended that the entire cable system be replaced once every four years irrespective of service conditions.</p> <p>NOTE Use magnifying glass here if necessary.</p>	<ul style="list-style-type: none"> • Owner (holds at least a sport pilot certificate) • LSA Repairman Inspection (only if ELSA) • LSA Repairman Maintenance • A&P • Repair Station <p>WARNING The inspection can be done by the above personnel but if any repairs are required, they need to be carried out by personnel authorized by the wing or trike manufacturer ONLY!</p>
Line Maintenance	Check Tubing Visually	<p>Check all tubing joints and fastener locations carefully. Visually look inside the sail for any bends in tubes or any cracks in any brackets connected to the tubes. If any cracks, dings or bends are found consult the manufacturer.</p> <p>WARNING In case of cracks, dings or bends discovered in any tubing on the wing, GROUND THE WING AND CONSULT THE WING MANUFACTURER OR TRIKE MANUFACTURER IMMEDIATELY!</p>	<ul style="list-style-type: none"> • Owner (holds at least a sport pilot certificate) • LSA Repairman Inspection (only if ELSA) • LSA Repairman Maintenance • A&P • Repair Station

Type	Action	Description	Personnel Authorized
Line Maintenance	Check the battens and symmetry	<p>Visually inspect the curvature of the wing very carefully to make sure it is symmetrical. If a turn has developed please follow the wing manual suggestion to tune the turn out. Battens should be checked on the batten chart. Please note tuning of the wing involves changing the profiles of certain battens up to 3/4". Note the asymmetrical battens in pencil on the chart. If any batten tips, etc. are broken or worn, replace them before flight.</p> <p style="text-align: center;">CAUTION</p> <p>You may have to de-tension the wing to take battens out. Refer to the AOI or the wing manual for instructions on de-rigging the wing. Do not try and force the batten in or out when the wing is tensioned.</p>	<ul style="list-style-type: none"> • Owner (holds at least a sport pilot certificate) • LSA Repairman Inspection (only if ELSA) • LSA Repairman Maintenance • A&P • Repair Station
Line Maintenance	Clean the wing	<p>Follow wing manual procedures to clean and wash the wing. In absence of this procedure in the wing manual, proceed as follows:</p> <ol style="list-style-type: none"> 1) Cover the trike base and engine area with trike cover or plastic sheets so water does not fall inside of it, or remove the wing from trike if desired. 2) Wash the wing with lukewarm water with a regular garden hose pressure. <p>DO NOT USE HARSH CHEMICALS OR DETERGENTS.</p>	<ul style="list-style-type: none"> • Owner (holds at least a sport pilot certificate) • LSA Repairman Inspection (only if ELSA) • LSA Repairman Maintenance • A&P • Repair Station

Please mark the aircraft logbook as “Initial 50-hour inspection completed”

2.3.4 Hundred (100) Hour/Annual Inspection (100-h)

NOTE

If unsure about how to do a certain task we recommend that you refer to FAA AC 43.13-1B for details.

NOTE

Please also refer to section 2.3.5 for component replacement schedule while performing this annual inspection.

WARNING

The checks listed in “Wing”, “Carriage Structure” and “Landing Gear” in this list should also be performed if a hard landing has been experienced and filed results saved and logged with aircraft logs to maintain airworthiness and SLSA status of your machine. Any item showing deformation indicates the aircraft has experienced extreme loads and a qualified mechanic (A&P, LSA Repairman Maintenance or higher) needs to do further analysis before declaring it safe and airworthy.

Type: 100 Hour or Annual or After Hard Landing Inspection

Authorization to Perform:

- LSA Repairman Inspection (only if ELSA)
- LSA Repairman Maintenance (SLSA or ELSA)
- A&P or higher
- Repair Station

Please print these pages and perform the inspection as listed every 100 hours or annually or after hard landing whichever comes first to maintain SLSA status of your aircraft.

Condition Inspection Checklist based on FAA FAR 43 Appendix D

Aircraft Make/Model: _____ S/N: _____

Engine Make/Model: _____ S/N: _____

Wing Make/Model: _____ S/N: _____

Date of Inspection: _____

TT Airframe: _____

TT Engine: _____

TT Wing: _____

Inspector: _____

Check all that apply:

_____ Owner _____ Operator _____ Pilot _____ A&P

_____ LSA Repairman Inspection (only if ELSA) _____ LSA Repairman Maintenance

_____ 100 Hour OR _____ Annual (whichever is less)

_____ After Hard Landing

Last Inspection performed:

Date: _____ Hours: _____

Scope and Detail of Items (As Applicable to the Particular Aircraft) to be **Included in Annual and 100-Hour Inspections.**

Ready the aircraft to be inspected

- Remove rear section, and engine cowling (if applicable).
- Separate wing from the carriage (See section 4 of AOI if necessary).
- Remove seats to inspect systems underneath.
- Thoroughly clean the aircraft and propulsion system.

Mark “P” for Pass or “F” Fail at each line _____

AIRCRAFT DATA

_____ **Aircraft Data Accuracy**

Verify data in aircraft logbooks matches the information found on data plate and registration.

WING

A NOTE ABOUT CABLES AND CABLE MAINTENANCE

The cables which support the wing’s airframe are critical components of the wings structure, and must be maintained in an air worthy condition. Cables, like other structural components on the wing, are typically designed with a structural safety factor of only about 50% above the expected maximum load. No significant loss in cable strength can be tolerated. A cable with even a single broken strand must be replaced before the wing is flown again. A cable which has been bent sharply enough to have taken a permanent set must also be replaced immediately. Some degree of fatigue due to repeated bending of cables is almost unavoidable in an aircraft that is assembled and disassembled. Even though these cables are stainless steel they are susceptible to corrosion.

_____ **Cable System**

The cables must be checked for broken/nicked wires (frays), corrosion, Nico and thimble condition. If any defect is observed, no matter how small, the cable in question **MUST BE REPLACED**. It is recommended that the entire cable system be replaced once every five (5) years or 500 hours irrespective of service conditions except backup cabling. Cables can be obtained from the wing manufacturer or assembled by a repair station with proper expertise and equipment.

A NOTE ABOUT SAIL STRENGTH

An annual Bettsometer test with a 0.045 - 0.047 inch diameter needle, with wing sails fitted and tensioned for flight is to be conducted Upper & lower surface: 3 lbs Stitches: 3 lbs using a 0.045 - 0.047 inch diameter hook, pull upwards. Besides the annual check there are several criteria for testing of sails dependent on the conditions that the sail fabric is exposed to. The pilot/operator of the aircraft is responsible for determining the level of exposure that the sail experiences. UV is the killer of sail cloth and is to be avoided as much as possible.

Annual testing is adequate except in cases where a harsh and exposed environment warrants more frequent testing. In such cases every 200 operating hours regardless of time (annual or not), the Bettsometer testing should be conducted to see if sail and stitch passes.

Keep an eye on the sail grommets/eyelets and all areas of the sail that are subject to extra stress, especially the wing keel section, the nose section of leading edge and the outer tip section of leading edge.

_____ Sail Check-Up

Checking the sail surface and seams.

There should be no cuts, ruptures, threadbare holes and torn seams on the sail. Any torn seams should be re-stitched. Cuts and ruptures on the leading edge and under of the sail that are not longer than 1.25" (30 mm) can be patched up with self- adhesive Dacron sail appropriately. The Dacron must be of a weight of not less than 100 g/m. Larger cuts and ruptures are to be repaired by stitching on a reinforcing piece of the same fabric (stitched along the edges). Any rupture shorter than 8" can be repaired in this manner, but more complicated repairs and **all cuts near the trailing edge** should be carried out in the workshop of producing company or approved service stations.

Tubing and Structure

Check all nuts, bolts, safety pins, and hardware on the wing.

Check all tubing visually for corrosion, straightness, dings cracks etc. If there is absolutely any doubt, check the tubing as described below in full tubing inspection.

Check all brackets and connections in the structure for cracks etc.

Full tubing inspection (at 500 hours since new and then every 250 hours thereafter). At 500 hours and then every 250 hours thereafter or if it is known that the wing has had hard landing or the trike has flipped over due to adverse weather conditions when outside, it is imperative that tubing and brackets be inspected fully with sail-off in the following manner:

To check the condition of the wing tubes the sail should be removed from the wing frame by unlocking all the fasteners that secures outside cabling and/or struts to the wing structure, removing the hang block as applicable so the keel pocket can slide through the keel tube, close the wing in so its in packed position and snaking the fabric off the structure. Then the tubes should be detached at the joints. The tubes are to be inspected visually. When there is suspicion of damage, the points in question should be inspected using a magnifying glass of (5-10) X magnification.

A straight edge may be used on the tubing to ascertain straightness. There should be no trace of corrosion, cracks, bends or dents.

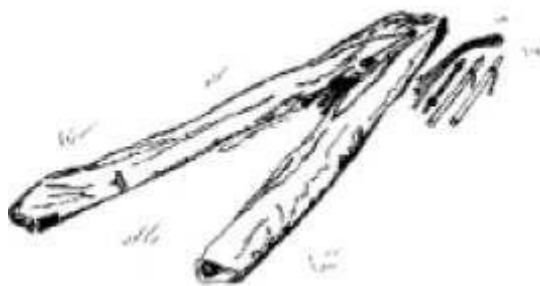

Take all battens out, remove rear lower flying wires from the keel, remove struts, Keel straps and hang block elements that hinder the sail from coming off the frame.



After closing the wing the sail can now be snaked out through the nose.

_____ **Fasteners**

Check all fasteners (bolts, screws, rollers, nuts, splint pins etc.) for corrosion. Any corroded/rusted fasteners should be replaced. Bolts should not be worn and/or bent. All bolts should be checked most thoroughly for cracks between the head and the bolt body. If any cracks are observed – **REPLACE IMMEDIATELY!**

_____ **Battens/Ribs and Batten Tips and Trailing Edge Tips or Cords**

The batten profiles should be checked against the template and the bends should be adjusted if necessary to the template. Please note the tuning of the wing may allow + or – of $\frac{3}{4}$ " height difference on certain battens which should be documented on the template in pencil. Check all the plastic batten heads and tails and replace if necessary. The batten templates can be ordered from the manufacturer. Only those battens that are known to be bent beyond the original template for wing tuning purposes and logged in aircraft maintenance log as such should be allowed to deviate from the manufacturer batten template.

If any of the batten tightening cords are torn or heavily worn they must be replaced. Any batten trailing edge tips that are worn should be replaced if applicable.

CARRIAGE/AIRFRAME

Carriage Structure:

_____ Hang Block Assembly

Hang block assembly should be checked for cracks, elongated holes, general condition and excessive unusual play.

Bolts should be checked for bends and cracks where head joins the rest of the bolt. Nuts should be checked for general condition and safety rings replaced if rusted or bent. Undercarriage hang block safety backup cable condition and attachments good.

Hang block assembly including all the bolts and nuts should be replaced **based on condition** and can be ordered from the manufacturer.

_____ Mast

General condition, all structural attachments condition good, and security of all attachments, tubing not bent. A water displacement compound or ACF-50 can be sprayed liberally inside the mast to prevent rusting. Wipe off excess.

_____ Compression Strut/Front Strut

General condition good with good upper and lower attachments. A straight edge may be used on the tubing to ascertain straightness.

_____ Base Tube/Trike Keel

General condition with structural attachments to front tube/triangle, mast/pylon, and front/back landing gear. A straight edge may be used on the tubing to ascertain straightness.

_____ Seat Frame

General condition with secure attachments to mast/pylon and base tube.

Landing Gear:

_____ **Main Landing Gear**

General condition, security and operation. Aluminum plate (leaf) landing gear in good condition and properly secured. Bolts that secure landing gear to the trike keel bracket. Bolts that secure axle brackets to leaf gear (no rust or corrosion).

_____ **Front Fork**

Nose wheel steering, security and reasonable play. Front fork springs in good condition and not sagging excessively. Fasteners not rusted. Plastic bushings securely pressed up into fork main tubes.

_____ **Hydraulic Disc Brakes**

Check discs for abnormal wear, brake pad wear, brake lines and reservoir for leakage.

_____ **Wheels**

Check for smooth operation, tightness, cracks, defects, condition of bearings and alignment.

_____ **Tires**

Check for pressure, wear, cuts and out of round.

Cockpit:

_____ **Loose Unsecured Items/Cleanliness**

Check for cleanliness and loose equipment that could become dislodged and go through the propeller.

_____ **Safety Belts**

Check for good condition, operation, secure attachment, and acceptable wear.

_____ **Windshield**

Check for deterioration, breakage/cracks and security.

_____ **Instruments**

Check for general condition and operation.

_____ **Flight Controls**

Check full range operation.

_____ **Belly Scoop**

The belly scoop can be cleaned easily with spraying water by removing the grill by undoing the fasteners holding it in place. A small hole can be drilled at the lowest point in the belly scoop fairing to facilitate drainage of water.

_____ **Engine Throttles and Choke** (if applicable)

Check for proper installation, smooth operation and locking. Use a cable oil applied with a cable oiler (commonly used on a dirt bike clutch cable) to use to lubricate throttle cable at the gas pedal end. Oiler may be used throughout the cable assembly to help lubricate in other area as well.

_____ **Controls and Systems**

Check all cockpit controls and systems for proper installation, general condition, apparent and obvious defects, and security of attachment.

_____ **Certificates, Documents and Placards**

All certificates, documents, placards, nameplates and airworthiness certificates are current and in aircraft.

Propulsion System:

NOTE

Please refer to the engine manual as well for the inspection sheet for the engine.

_____ **Basic Maintenance**

Basic maintenance items general condition and within recommended schedule (oils, cooling fluids, fuel filter/gascolator, air filters, and spark plugs as required).

_____ **Leaks**

Inspect engine section for visual evidence of excessive oil, fuel, exhaust or hydraulic leaks.

_____ **Torque of Engine Components**

Torque induction, exhaust, and cylinder heads to specifications as required. Refer to Rotax engine manual.

_____ **Fuel System**

Fuel tank general condition, fuel pick up screen, fuel tank vent, fuel lines to carburetor/fuel rail, Fuel pump, fuel flow sensor, fuel line condition, fuel filter and fuel system general condition and security.

NOTE

Replace/clean fuel filter in the gascolator every 100 hours. Replace fuel lines every 5 years using Aeroquip fuel lines. The fuel lines with fire sleeves have to be replaced with similar assemblies provided by the manufacturer.

_____ **Induction Inlet Boots** (if applicable)

Check for cracks and leaks

_____ **Cylinder Compression**

Check as required. Record values. Refer to Rotax engine manual

_____ **Evidence of Metal Particles**

Check for Metal particles or foreign matter on screens and sump drain plugs.

_____ **Engine Mounts**

Check for cracks, and security. Must be replaced every 400 hours.

Flexible Vibration Dampeners

Check for general condition and security. Look for large cracks in aged or dried out rubber. Replace every 400 hours with new ones from the factory.

Engine Controls

Synchronize Carbs on Rotax engines if applicable (refer to Rotax manuals) Check general condition, travel, and safety wired where required.

Lines, Hoses, and Clamps

Check for leaks, condition and looseness.

Exhaust

Check for cracks, and proper attachment. Hardware in good condition.

NOTE

Replace exhaust hardware on condition.

Engine Cowling

Check for cracks, defects and security.

Propeller Assembly

Check assembly for cracks and nicks. Torque propeller and gearbox to specifications.

Propeller Balance, Pitch and Tracking

Refer to propeller manual for tolerances.

Accessories and Systems

Check for proper installation, general condition, defects, and secure attachment.

Throttle and choke Cables (if applicable)

Check and lubricate.

Refer to Rotax Engine Manual

Follow 100 hour manufacture's maintenance specifications

Systems:

_____ **Radio and Electronic Equipment**

Check for secure mounting and working properly.

_____ **Radio Antenna Position**

Check for security and operation. Replace antenna installation tape, if applicable, and if necessary with a new one.

_____ **Electric System Wiring**

Check wiring and conduits for proper routing, secure mounting against vibration, and obvious defects. Check sensor wire ends at the RDAC module, if applicable, and make sure connections are good there.

_____ **Batteries**

Check for proper installation, charge, secure installation and general condition. Change lead acid battery as needed (every 2 years is recommended). Replace Lithium battery using EarthX 24D or 36D ONLY as needed (recommended every 5-8 years).

_____ **All Other Systems**

Check for proper attachment, security, and operation.

_____ **Ballistic Parachute**

Check for proper attachment, routing, and general condition and schedule for re-packing or rocket replacement.

_____ **Roll Trim** (if applicable)

Check for any slop in hinge and turn buckle arm. Check for proper operation and over all security

Other:

_____ **Other Items**

That are not listed here for proper installation, condition, operation or safety of flight.

2.3.5 Component Replacement Schedule

Airframe	Lifespan	
U-Style Hang Block Assembly 1/4" hoop	300 H	5 years
CNC Hang Block halves/ 4 AN6-34 bolts	3,000H/1,000H	10yrs/5yrs
Hang Bolt (x1)	400 H	3 years
All nuts and bolts of mast/pylon	1000 H	5years
All brackets like the compression strut securing brackets etc.	On condition	n/a
Front suspension bolts that limit fork travel/nuts Rear suspension securing bolts to base tube (x4) Rear axle carrier to landing gear securing bolts (x8) Rear axle to axle carrier securing bolt	500 H 1000H 1000H 1000 H	5 years 5 years 5 years 5 years
Front Fork Shock Absorbers (rubber inside the fork tubing)	500 H	n/a
All other airframe ball-joints, bolts and nuts	On condition	n/a
Brake Lines	On condition	n/a
Mast/Pylon	2000 hours	n/a
Tires	On condition	n/a
Seatbelts	On condition	n/a
Flush and bleed the brakes using correct tool and Automatic Transmission Fluid from a sealed container (aka 5606 milspec) for Revo	If brakes start to feel spongy	5 years
All rear suspension components (landing gear)	1000 H or if tire/wheel is not perpendicular to ground when empty with wing installed.	
Metal Airframe components	On condition for trike carriage and every 1500 H for wing tubing skeleton and sail.	
Wing Cables	As needed on condition or 500 hours or 5 years	

Propulsion Area	Lifespan	
Fuel – Line/hose	N/A	On condition/ 10 years
Fuel sight gauge	N/A	2 Years
Fuel – Filter (Use only fuel filter element approved and proper for the type of fuels used like Ethanol based gas). Clean Gascolator filter element. If its conditions is undamaged, it does not require replacement	100 H	1 year
Fine fuel filter	n/a	400 hours
Battery lead acid/ Lithium	n/a	On condition
Hose – Oil (Aeroquip or Parker hose)	n/a	On condition
Hose – Coolant	n/a	On condition
Rubber Barry Mounts (all) recommended mounts	400 H	5 years
Cables and housing – Throttle and Choke	500 H	n/a
Engine Mount Nuts and bolts	1000 H	n/a
Muffler springs	500 H	
All engine mount components	On Condition	
Fuel Tank	On condition	n/a

Propulsion Area – Replacement Items	Lifespan
Engine overhaul or replacement	As specified by the engine manual
Chute repack or replacement	As specified by manufacturer
Propeller	As specified by propeller manufacturer

Materials – Trike Carriage	
Frame	4130 Chromolly .125 wall thickness, TIG welded and heat treated for stress relief
Landing Gear solid Leaf	7075-T6
Mast	4130 Chromolly .090 wall thickness, TIG welded and heat treated for stress relief
Engine Mount	6061-T6
Other welding	TIG

3 STRUCTURES

3.1 General

This section provides a description of and instructions for the maintenance, repair, and alteration of the aircraft primary structures.

3.2 Structures

3.2.1 Wing

The REVO can be flown with multiple trike wings approved by Evolution Aircraft, Inc. The aircraft as typical of its category of aircraft has a universal connection point on which different wings can be secured on top of the mast/pylon.

The wing consists of a skeleton structure composed of:

1. Wing keel
2. Leading edge tubes
3. Cross tube or cross bar
4. Downtubes
5. Control bar
6. Cabling system including main flying wires
7. Struts
8. Sprogs
9. Hang block assembly
10. Battens

The sail of the wing is generally either Dacron, Mylar or Trilam. PX-20 is also used to re-enforce the sail.

3.2.1.1 Maintenance

General maintenance of the wing can be accomplished using strategies suggested under inspections and in combination with the wing manual. Washing should be with warm low pressure garden hose water. ACF-50 or similar should be used in pivot areas and on hardware to prevent from corrosion and rust as suggested in the routine inspections checklists. For who can do this maintenance please refer to 50 hour interval maintenance checklists.

3.2.1.2 Repair

Sail Surface and Seams

Type: Line Maintenance

Authorization to perform: Owner (holds at least a sport pilot certificate), LSA Maintenance Inspection, LSA Maintenance Repairman, A&P, Repair Station

Description:

There should be no cuts, ruptures, threadbare holes and torn seams on the sail. Any torn seams should be re-stitched. Cuts and ruptures on the leading edge and bottom surface (BS) of the sail that are not longer than 1.25” (30 mm) can be patched up with self- adhesive Dacron sail appropriately. The Dacron must be of a weight of not less than 100 g/m. Larger cuts and ruptures are to be repaired by stitching on a reinforcing piece of the same fabric (stitched along the edges). Any rupture shorter than 8” can be repaired in this manner.

Complicated Sail Repairs

Type: Heavy Maintenance

Authorization to perform: Task Specific, original wing manufacturing factory or a professional sail loft familiar with WSC wing sail repair.

Description: More complicated repairs and all cuts near the trailing edge should be carried out in the workshop of producing company or approved service stations with specific knowledge and authorization to perform sail repair from the manufacturer.

Sail Strength Check

Type: Heavy Maintenance

Authorization to perform: LSA Repairman Maintenance, A&P, Repair Station

Description: An annual Bettometer test with a 0.045 – 0.047 in diameter needle, with wing sails fitted and tensioned for flight is to be conducted.

Upper & lower surface: 3 lbs

Stiches: 3 lbs using a 0.045 – 0.047 in diameter hook, pull upwards.

Besides the annual check there are several criteria for testing of sails dependent on the conditions that the sail fabric exposed to. The pilot/operator of the aircraft is responsible for determining the level of exposure that the sail experiences. UV is the killer of sail cloth and is to be avoided as much as possible.

Annual testing is adequate except in cases where a more harsher and exposed environment warrants more frequent testing. In such cases every 200 operating hours regardless of time (annual or not), the Bettometer testing should be conducted to see if the sail and stitching passes.

Keep an eye on the sail grommets/eyelets and all areas of the sail that are subject to extra stress, especially the wing keel section, the nose section of the leading edge and the outer tip section of the leading edge.

Full Tubing Inspection

Type: Heavy Maintenance

Authorization to perform: LSA Repairman Maintenance, A&P, Repair Station

Description: To check the condition of the wing tubes the sail should be removed from the wing frame by unlocking all the fasteners that secures outside cabling and /or struts to the wing structure. Removing the hang block, as applicable, so the keel tube can slide through the keel pocket. Close the wing in so it is in packed position and snaking the fabric off the structure. Then the tubes should be detached at the joints. The tubes are to be inspected visually. When there is suspicion of damage, the points in question should be inspected using a magnifying glass of 5-10X magnification. A straight edge may be used on the tubing to ascertain straightness. There should be no trace of corrosion cracks, bends or dents.

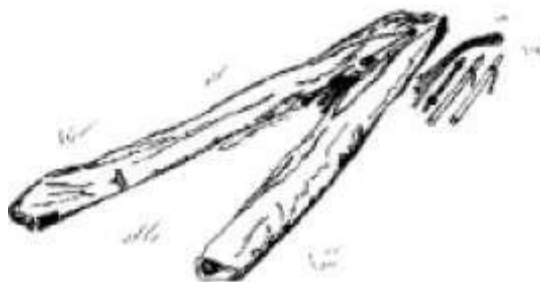

Take all battens out, loosen all fasteners, struts, cabling, cross tube and leading edge junction, hardware, straps and hang block elements that hinder the sail from coming off the tube structure.



After closing the wing, the sail can now be snaked out through the nose.

Fasteners

Type: Line Maintenance

Authorization to perform: Owner (holds at least a sport pilot certificate), LSA Repairman Inspection (only if ELSA), LSA Repairman Maintenance, A&P, Repair Station

Description: Check all fasteners (bolts, screws, rollers, nuts, splint pins, etc.) for corrosion. Any corroded fasteners should be replaced. Bolts should not be worn and/or bent. Key bolts should be checked most thoroughly for cracks between the head and the bolt body. These are the bolts at the control bar side and bottom points, the cross tube tensioning cable attach point and the rear cable attachments point on the keel tube. If any cracks are observed – **REPLACE IMMEDIATELY!**

Batten/Ribs and Batten Tips and Tailing Edge Tips or Cords

Type: Line Maintenance

Authorization to perform: Owner (holds at least a sport pilot certificate), LSA Repairman Inspection (only if ELSA), LSA Repairman Maintenance, A&P, Repair Station

Description: The batten profiles should be checked against the template and the bends should be adjusted if necessary. Check all the plastic batten heads and tails and replace if necessary. Batten templates can be ordered from the manufacturer. Only those battens that are known to be bent beyond the original template for wing tuning purposes and logged in the aircraft maintenance log should be allowed to deviate from the manufacturers batten template. Battens are numbered in increasing order from the tip inward starting from 1.

If any of the batten tightening cords are torn or heavily worn they must be replaced. Any batten trailing edge tips that are worn should be replaced if possible.

3.2.1.3 Alteration

No alteration of the wing structure is allowed except by the manufacturer. All tubing should be bought from the wing manufacturer if replacement is deemed necessary.

3.2.2 Carriage

The Revo trike carriage is a two seat tandem WSC aircraft. The layout is typical for two seat trike design, with the pilot, passenger and pod being suspended by a triangular frame, hanging from the top of the mast about the pitch and roll axes, to provide for weight shift control.

The cockpit has a quick release windscreen for improved wind deflection and the wheel pants include large integrated aerodynamic fins for carriage yaw stability.

WARNING

The wheel pants are REQUIRED in order to fly the REVO

The main gear suspension consists of one piece Aluminum plate leaf like landing gear that is covered on both sides with aerodynamic composite fairings.

Seats are composite bucket seats with custom purpose built cushion seats and upholstery attached for comfort and there is a 3-point harness system for both pilot and passenger with the shoulder harness being a re-coil harness system.

All wheels are equipped with hydraulic disc brakes with fluid reservoir near the front fork. Storage space for baggage under the front seat on each side of the base tube (center bottom keel tube) of the trike carriage can be further accessed from the front bucket seat by lifting off the Velcro attached cushion.

Under the back seat is a 14+ gallon (US), 53+ liter fuel tank, rubber mounted to the frame of the trike carriage.

Optionally an ASTM compliant model ballistic Chute can be fitted very cleanly inside the trike pod behind the fuel tank, with the handle located to the side well within reach of the pilot and co-pilot.

3.2.2.1 Maintenance

The trike carriage can be maintained by following strategies and inspections as suggested in section 2 of this manual and in the AOI and following the replacement cycle.

3.2.2.2 Repair

Mast/Pylon

Type: Line Maintenance

Authorization to perform: LSA Repairman Maintenance, A&P, Repair Station

Description: To prevent wear, and to allow a degree of flexibility during wing attachment, the lower mast hinge point is supported against a solid Delrin block attached to a solid CNC Aluminum mast junction. It is locked in position by a custom fastener with a large handle for hand tightening. Care should be taken not to bend the mast or put undue stress on it during wing attachment or by moving the trike (especially backwards) and allowing the forks to lock from side to side making the wing rotate abruptly from side to side. In case of damage this item should be replaced by ordering one from the manufacturer.

If the mast becomes bent, kinked or damaged such as a cracked weld, replacement is the only

option. Removing the mast, assuming the wing and the seat pan has been removed, consists of cutting the safety cable below the mast and removing the hinge bolt. If applicable removal of the plastic plug for the speed trim can easily be removed using a pin puller. These plugs are GM factory plugs. Then remove the upper compression strut fitting and then drill the SS rivets that hold the Delrin mast head in place. The new mast will include 2 new rivets and the mast head can be swapped over to the new part. The compression strut bracket if re-using will then be swapped over. Then install a new mast pivot bolt and secure the mast upright with the through bolt that secures it. Run a fish down the mast to run the trim cable back through. Then if the aircraft is equipped with a BRS (Ballistic Recovery System), remove the BRS in order to connect the new safety cable around the main frame and swage on the new supplied Nico press. Then slide the BRS back in. When removing the BRS, it will only be necessary to unscrew the 2 band clamps. Then slide out the BRS onto a chair or similar while keeping the rocket connected to the handle. The handle line will need to be run under the gas tank when the BRS is slid out of the body. Please refer below to **SAFETY CABLE** for instruction.

NO.	NOTES	REVISIONS			
1	DEBUR ALL SHARP EDGES.	REV.	DESCRIPTION	DATE	APPR.

ITEM NO.	PART NUMBER	DESCRIPTION	QTY.
1	300-0137	MAST MOUNT BLOCK	1
2	300-0138	MAST CRADLE	1
3	300-0139	MAIN MAST TUBE	1
4	300-0140	MAST BUSHING SHORT	2
5	300-0141	MAST BUSHING LONG	1
6	300-0142	UPPER WEAR BLOCK	1
7	300-0154	SEAT BELT RETAINER	2

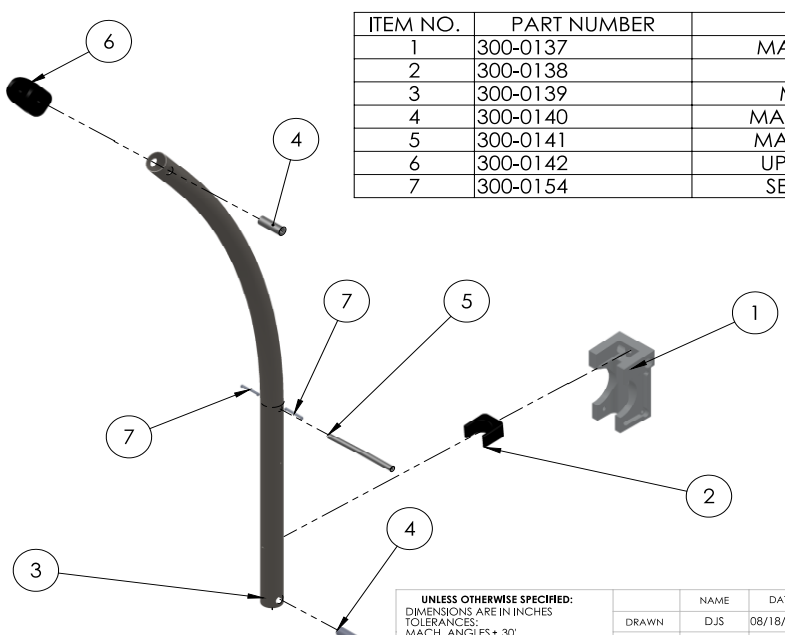

<p>UNLESS OTHERWISE SPECIFIED: DIMENSIONS ARE IN INCHES TOLERANCES: MACH. ANGLES ± 30° BEND ANGLES ± 2° TWO PLACE DECIMAL ± .030 THREE PLACE DECIMAL ± .010 HOLES: Ø .XXX +.004/.001</p> <p>PROPRIETARY AND CONFIDENTIAL THE INFORMATION CONTAINED IN THIS DRAWING IS THE SOLE PROPERTY OF THE EVOLUTION AIRCRAFT COMPANY. ANY REPRODUCTION IN PART OR AS A WHOLE WITHOUT THE WRITTEN PERMISSION OF EVOLUTION AIRCRAFT COMPANY IS PROHIBITED.</p>	MATERIAL	NA	NAME	DJS	DATE	08/18/2009	<p>EVOLUTION TRIKES ZEPHYRHILLS, FLORIDA USA </p> <p>TITLE: MAST ASSEMBLY</p>		
	MATL DIM:	NA	DRAWN	DJS	08/18/2009	CHECKED		LM	08/18/2009
	CUT LEN:	NA	ENG APPR.	AF	08/18/2009	PROJECT: REVO			
	FINISH	POWDERCOAT	NAS523 RIVET CODE		DASH NO FOR DIA: C = CSINK D = DRIFLE FIG-NO. OF SHEETS TO BE DWGPLED			DASH NO. FOR DIA: N=MG HD. NEAR SIDE F=MG HD. FAR SIDE DASH NO. LENGTH W=SPOTWELD.	
C:\Users\PhotoPilot\Dropbox (Personal)\EVOLUTION AIRCRAFT\REVO\REVO ENGINEERING\REVO MODEL AND DRAWINGS\MAIN FRAME ASSEMBLY\COMPLETE\		DO NOT SCALE DRAWING		SCALE: 1:12	WEIGHT: 17.54 LBS	SHEET 1 OF 2	REV A		

Safety Cable

Type: Line Maintenance

Authorization to perform: LSA Repairman Maintenance, A&P, Repair Station

Description: The mast/pylon has an internal stainless steel safety cable. This cable travels the folding mast tube length and attaches to the safety strap fastener (Jesus cable) that goes around the wing keel tube. If the cable ever needs replacement it can be re-made locally by an A&P and re-run through the mast. Please refer to FAA AC 43.13-1B for details on how to make steel and stainless steel aircraft cable assemblies.

Rear Landing Gear

Type: Line Maintenance

Authorization to perform: LSA Repairman Maintenance, A&P, Repair Station

Description: The rear landing gear consists of a solid one piece Aluminum spring plate leaf that attaches to the base/keel tube of the trike via a steel bracket and fasteners. It provides suspension function as well and is clad under aerodynamic composite fairing. If there is damage to the landing gear, it needs to be replaced by purchasing one from the manufacturer. The landing gear may not appear to be damaged in some cases. Due to the nature of aluminum, it has a cycle life when it is flexed, this lifespan of the part will far exceed the 1000 hour replacement intervals. However, when a hard landing occurs the aluminum gear can be stressed and yielded which will generally not make it fail at that moment, but instead make the part no longer airworthy, and reduce the life span to a fraction of its original intended cycle life. Therefore replacement of this component is critical if it fails the following test.

In order to assess if a new landing gear is needed follow these steps:

1. With the wing on and no one in the trike, roll the trike carriage on a flat surface.
2. Visually inspect the angle of the tire/wheel assembly and see if the wheel is 90° to the ground or if the tops of the tires are leaning inwards. If it possible, but highly unlikely the axle or axle carrier is bent or broken giving this effect, but check these components as well as they will alter the test. However, it is also highly unlikely if the axle or axle carrier is bent or broken, that the landing gear has not been yielded.
3. If the tops of the tires are aiming inwards by more than 2° the landing gear fails this test and requires replacement. It is recommended if the tires are less than 90° to the ground that the landing gear be replaced.

To remove the landing gear:

1. Remove the gear fairing bolt and slide the fairing back enough to access the wheel pant bracket fasteners. Remove the wheel pant by undoing 4 fasteners holding it in place outside and inside of tire track. Be careful to disconnect the weather proof wiring connectors from the wheel pants if landing lights and/or Nav and strobe lights are affixed on the wheel pants
2. Using a pulley mechanism or engine hoist, lift the trike carriage up slightly with a soft tie around the intake manifolds. If equipped with an engine enclosure or engine cap, remove it to access the top of the engine.
3. Unfasten the hydraulic disc brake line off the rear calipers.
4. Take the wheel off completely by removing just the axle through bolt that goes through the axle carrier.
5. Remove the axle carrier by unfastening the 4 AN-4 bolts.
6. Remove the fiberglass fairing gently by pulling it out after removing the rubber trim around the opening. It is a good idea to use blue painters tape to protect the landing gear covers. It will be necessary to angle the gear cover so that the rear corner comes out first.
7. Unfasten the 4 AN-5 bolts securing the gear to the trike's base tube. This may require loosening the moving the BRS out next to the trike carriage which may in turn require taking off the seat pan on top and taking off BRS circular bands and sliding the BRS canister out as far as the rocket handle cable will allow. Temporarily routing the cable under the gas tank will allow additional travel of the BRS canister from the aircraft without disconnecting the handle from the body. Place the BRS on a chair or similar next to the body.
8. Carefully drop the main gear 1" and slide forward towards the larger part of the gear leg opening in the body for better clearance and slide the main gear out.
9. Axles if bent can be replaced by taking them out of the axle carriers by removing the AN-4 bolt holding the axle in place and putting the new axle from the manufacturer in. Thin slices of shims may be used to take up any slop between the axle and axle carriers if there is any play in the assembly.
10. Install new landing gear and use proper torque per this manual.

Aircraft Maintenance Manual – Evolution Aircraft, Inc. REVO 6.2

NO.	NOTES	REVISIONS			
1	DEBUR ALL SHARP EDGES.	REV.	DESCRIPTION	DATE	APPR.

ITEM NO.	PART NUMBER	DESCRIPTION	QTY.
1	200-0310	AXLE CARRIER ASSEMBLY	1
2	200-0300	WHEEL PANT BRACKET	1
3	300-0153	MAIN LANDING GEAR	1
4	200-0340	WHEEL PANT SUPPORT ASSEMBLY	1

<p>UNLESS OTHERWISE SPECIFIED: DIMENSIONS ARE IN INCHES TOLERANCES: MACH. ANGLES ± 30' BEND ANGLES ± 2° TWO PLACE DECIMAL ± .030 THREE PLACE DECIMAL ± .010 HOLES: Ø .XXX +.004/.001</p> <p>PROPRIETARY AND CONFIDENTIAL THE INFORMATION CONTAINED IN THIS DRAWING IS THE SOLE PROPERTY OF THE EVOLUTION AIRCRAFT COMPANY. ANY REPRODUCTION IN PART OR AS A WHOLE WITHOUT THE WRITTEN PERMISSION OF EVOLUTION AIRCRAFT COMPANY IS PROHIBITED.</p> <p>MATERIAL: NA MATL DIM: NA CUT LEN: NA FINISH: NA</p>	<table border="1" style="width: 100%; border-collapse: collapse;"> <tr><td>NAME</td><td>DATE</td></tr> <tr><td>DRAWN: DJS</td><td>08/18/2009</td></tr> <tr><td>CHECKED: LM</td><td>08/18/2009</td></tr> <tr><td>ENG APPR: AF</td><td>08/18/2009</td></tr> </table> <p>PROJECT: REVO NAS523 RIVET CODE</p> <p>BASIC CODE C=SKINK D=DIMPLE FIG=NO. OF SHEETS TO BE DIMPLED</p> <p>DASH NO FOR DIA. N=MFG HD. NEAR SIDE F=MFG HD. FAR SIDE DASH NO. LENGTH W=SPOTWELD.</p>	NAME	DATE	DRAWN: DJS	08/18/2009	CHECKED: LM	08/18/2009	ENG APPR: AF	08/18/2009	<p style="text-align: center;">EVOLUTION TRIKES ZEPHYRHILLS, FLORIDA USA </p> <p>TITLE: LANDING GEAR ASSEMBLY</p> <table border="1" style="width: 100%; border-collapse: collapse;"> <tr> <td>SIZE</td> <td>PART NO.</td> <td>REV</td> </tr> <tr> <td style="text-align: center;">A</td> <td style="text-align: center;">100-0300</td> <td style="text-align: center;">A</td> </tr> </table>	SIZE	PART NO.	REV	A	100-0300	A
NAME	DATE															
DRAWN: DJS	08/18/2009															
CHECKED: LM	08/18/2009															
ENG APPR: AF	08/18/2009															
SIZE	PART NO.	REV														
A	100-0300	A														

C:\Users\PhotoPilot\Dropbox (Personal)\EVOLUTION AIRCRAFT\REVO\REVO ENGINEERING\REVO PNG\ DO NOT SCALE DRAWING SCALE: 1:8 WEIGHT: 18.59 LBS SHEET 1 OF 1





Front and Rear Wheels

Type: Line Maintenance

Authorization to perform: Owner (holds at least a sport pilot certificate), LSA Repairman Maintenance, A&P, Repair Station

Description: The REVO can have Air Trac 600 or 700 series 6-ply aircraft tires. Recommended pressure is 18 to 35 psi on the Air Trac tire. Both tires are used as tubeless on a heavy duty split wheel with an O- ring in the middle. The O-ring can be greased and bead seal is recommended for the tire/wheel contact point.

To change the tires:

1. Remove the wheel pant off (To do that it may be necessary to slide the landing gear fairing back by loosening bottom fastener and sliding fairing back).
2. Jack the plane up carefully so as to not destroy the fiberglass. A very small jack can be used at the axle carrier or a hoist to hang the trike up slightly can be used.
3. Remove the wheel securing fasteners, and wheel pant bracket and take the wheel off.
NOTE the wheel is a three piece held together by 6 bolts and nuts with an O-ring in the middle for sealing.
4. After deflating the tire use a bead breaker to break the tire from the wheel.
5. Remove the 6 bolts form the wheel and split into 2 halves. It is also possible to leave the wheel assembled. Force will be required to get the old tire off and the new tire on.
6. Put the new tire on one side of the rim and line up the filler valve with the red dot on the side of the tire for proper balance.
7. Slide the second side of the rim on by lining up with the bolts properly with greased O-ring in the center of the split rims.
8. Apply bead sealer to the wheel and seal the tire against the rim by pumping air into the tire. Using a tight belt to squeeze the tire along the center of its circumference may be needed to ensure enough contact to allow the air to seat the tire.
9. Gently slide the wheel pant back on and fasten all the fasteners using removable Loctite where necessary (4 wheel pant fasteners). Install calipers and rotor as required.
10. Re-attach the wheel pant (connect electric plugs if applicable).







Front Fork

Type: Heavy Maintenance

Authorization to perform: LSA Repairman Maintenance, A&P, Repair Station

Description: The front fork is a telescopic design. The structure is 4130 Chromolly steel main bodies with stainless steel internal struts which compress springs inside. CNC Aluminum 6061-T6 Triple trees hold the SS legs together and clamp across the legs. CNC Aluminum 6061-T6 axle knuckles hold a hardened 3/4” hollow axle.

If the structure is damaged it should be replaced by ordering one from the manufacturer. To take the fork off, the front wheel and brake assembly needs to be removed, the neoprene front fork may be left in place, foot pedals removed by sliding them forward off their track after removing the stop pins, the fork tubes will drop by loosening the 8 allen head bolts that clamp them into the triple trees. The triple trees remove by removing the large 1/2” pivot bolt.

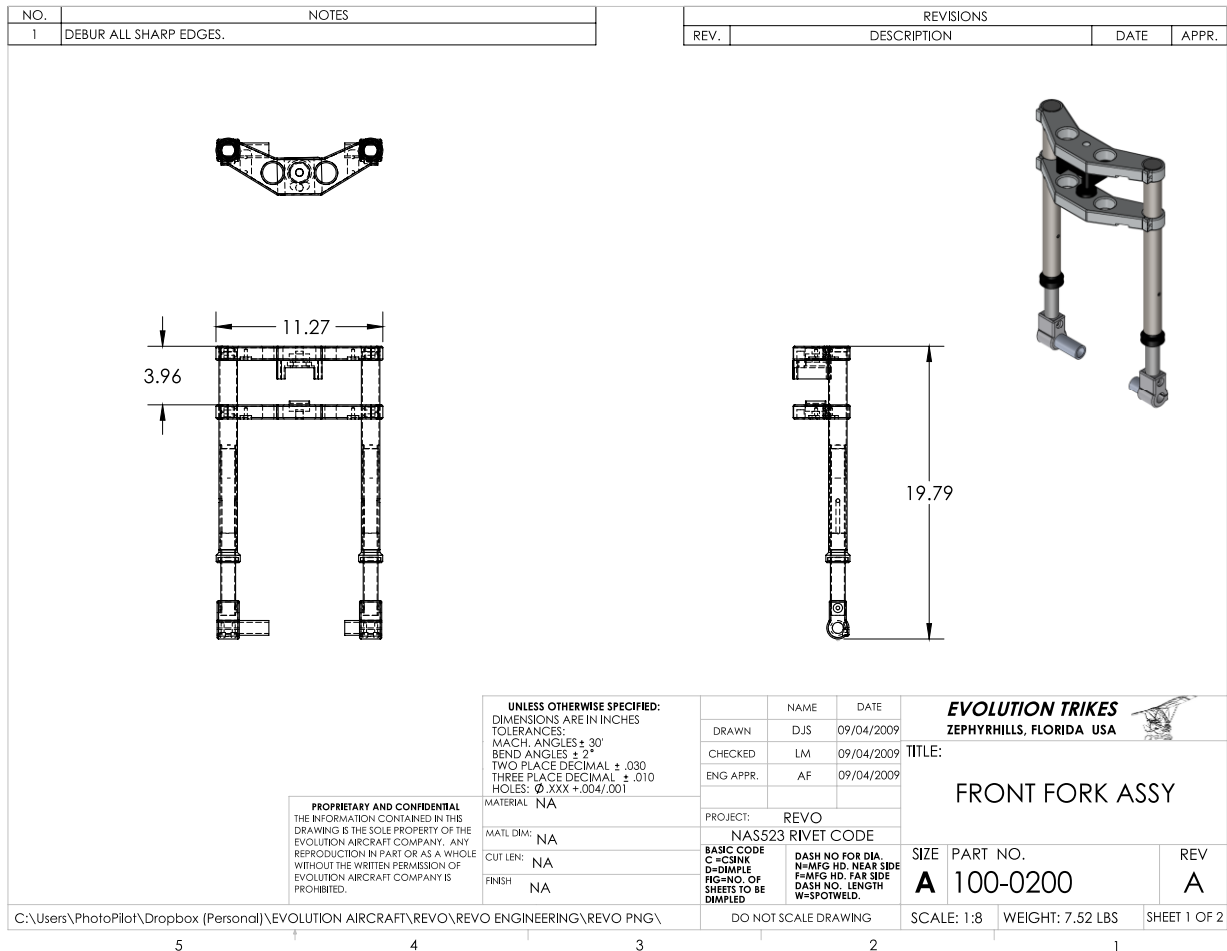

Seats

Type: Line Maintenance

Authorization to perform: Owner (holds at least a sport pilot certificate), LSA Repairman Inspection (only if ELSA), LSA Repairman Maintenance, A&P, Repair Station

Description: Seats are composite one-piece molded bucket seats. The front seat has a pivoting backrest. Composite honeycomb structure provides floor board for the passenger to step into the trike carefully. For composite repair please consult a manual for fixing composites as it is out of the scope of this manual or consult a composite professional.

Seat Covers

Type: Line Maintenance

Authorization to perform: Owner (holds at least a sport pilot certificate), LSA Repairman Inspection (only if ELSA), LSA Repairman Maintenance, A&P, Repair Station

Description: Manufactured of strong thick vinyl and foam shaped to contour are held in place by Velcro. The seats can be taken off, cleaned if necessary. Any repairs can be done by a qualified seamstress.

Seat Belts

Type: Line Maintenance

Authorization to perform: Owner (holds at least a sport pilot certificate), LSA Repairman Inspection (only if ELSA), LSA Repairman Maintenance, A&P, Repair Station

Description: Revo provides a 3-point harness with adjustable lap belts and re-coil shoulder harness for both pilot and passenger. The belts have quick release buckles and are ASTM compliant. Any cuts in the webbing require replacement of the belts.

Trike Fairing/Pod

Type: Line Maintenance

Authorization to perform: Owner (holds at least a sport pilot certificate), LSA Repairman Inspection (only if ELSA), LSA Repairman Maintenance, A&P, Repair Station

Description: The Revo has a very clean and aerodynamic fairing made from fiberglass and carbon fiber. It requires washing and waxing at consistent intervals to maintain its finish. To repair it please consult a composite repair manual as that is out of the scope of this manual.

To remove the front pod:

1. Remove seat pan.
2. A hoist or engine hoist should use a soft tie around the exposed main frame to elevate the front wheel
3. Disconnect the brake line from the front caliper
4. Loosen the 8 Allen heads and drop the fork tubes with wheel attached.
5. Remove the compression strut (front strut).
6. Remove the compression strut bracket.
7. Disconnect the pitot tube hose.
8. Remove all fasteners at the bulkhead.
9. Remove body mount attached to inside of tear drop.

Instrument Console

Type: Line Maintenance

Authorization to perform: Task Specific – fiberglass repair expertise required from a professional shop

Description: Is part of the fairing of the trike body and is made out of fiberglass and carbon fiber.

Compression Strut/ Front Strut

Type: Line Maintenance

Authorization to perform: Owner (holds at least a sport pilot certificate), LSA Repairman Inspection, LSA Repairman Maintenance, A&P, Repair Station

Description: Made out of Stainless Steel, this tube experiences some tension in normal flight and compression on hard landings. If damaged it should be replaced by ordering it from the manufacturer.

NO.	NOTES		REVISIONS			
1	DEBUR ALL SHARP EDGES.		REV.	DESCRIPTION	DATE	APPR.
ITEM NO.	PART NUMBER	DESCRIPTION	QTY.			
1	300-0143	PIVOT BLADE (FEMALE)	2			
2	300-0144	PIVOT BLADE (MALE)	2			
3	300-0149	COMPRESSION STRUT KNUCKLE (FEMALE)	1			
4	300-0150	COMPRESSION STRUT KNUCKLE (MALE)	1			
5	300-0148	CHANNEL MOUNT	1			
6	PIP Pin- AVIBank 4M1.00		1			
7	300-0147	TENSION TUBE (LOWER)	1			
8	300-0145	TENSION TUBE (UPPER)	1			
9	300-0146	TENSION TUBE SLEEVE	1			
10	PIP Pin- AVIBank 3-16	3/16" Diameter	2			
11	300-0262	COMPRESSION STRUT SPACER	1			

UNLESS OTHERWISE SPECIFIED:
 DIMENSIONS ARE IN INCHES
 TOLERANCES:
 MACH. ANGLES ± 30°
 BEND ANGLES ± 2°
 TWO PLACE DECIMAL ± .030
 THREE PLACE DECIMAL ± .010
 HOLES: Ø.XXX +.004/.001

PROPRIETARY AND CONFIDENTIAL
 THE INFORMATION CONTAINED IN THIS DRAWING IS THE SOLE PROPERTY OF THE EVOLUTION AIRCRAFT COMPANY. ANY REPRODUCTION IN PART OR AS A WHOLE WITHOUT THE WRITTEN PERMISSION OF EVOLUTION AIRCRAFT COMPANY IS PROHIBITED.

ANODIZE - MIL-A-8625, CLASS 2, CLEAR

NAME	DATE
DRAWN: DJS	08/15/2009
CHECKED: LM	08/15/2009
ENG APPR.: AF	08/15/2009
PROJECT: REVO	
NAS523 RIVET CODE	
BASIC CODE C=CSINK D=DIMPLE FIG=NO. OF SHEETS TO BE DIMPLED	DASH NO FOR DIA. N=MFG HD. NEAR SIDE P=MFG HD. FAR SIDE DASH NO. LENGTH W=SPOTWELD.
SIZE A	PART NO. 200-0100
REV A	

C:\Users\PhotoPilot\Dropbox (Personal)\EVOLUTION AIRCRAFT\REVO\REVO ENGINEERING\REVO PNG\ DO NOT SCALE DRAWING SCALE: 1:12 WEIGHT: 5.22 LBS SHEET 1 OF 1

Lower Trike Frame

Type: Heavy Maintenance

Authorization to perform: LSA Repairman Maintenance, A&P, Repair Station

Description: Made out of welded .125 wall thickness 4130 Chromolly, this is the main weight bearing structure of the carriage. If damaged it should be completely replaced with another one from the manufacturer. Main frame replacement must be done at the factory. The trike must be shipped back to Evolution Aircraft Inc.

NO.		NOTES	REVISIONS			
1		DEBUR ALL SHARP EDGES.	REV.	DESCRIPTION	DATE	APPR.

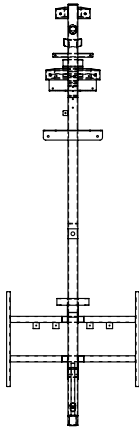
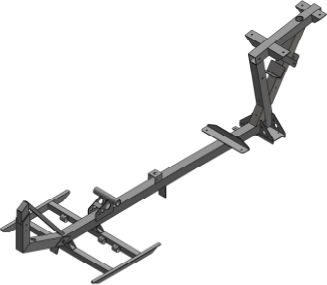
<p>UNLESS OTHERWISE SPECIFIED: DIMENSIONS ARE IN INCHES TOLERANCES: MACH. ANGLES ± 30' BEND ANGLES ± 2° TWO PLACE DECIMAL ± .030 THREE PLACE DECIMAL ± .010 HOLES: Ø XXX ± .004 / .001</p>		NAME	DATE	<p>EVOLUTION TRIKES ZEPHYRHILLS, FLORIDA USA </p>										
	<p>PROPRIETARY AND CONFIDENTIAL THE INFORMATION CONTAINED IN THIS DRAWING IS THE SOLE PROPERTY OF THE EVOLUTION AIRCRAFT COMPANY. ANY REPRODUCTION IN PART OR AS A WHOLE WITHOUT THE WRITTEN PERMISSION OF EVOLUTION AIRCRAFT COMPANY IS PROHIBITED.</p>	<p>MATERIAL: 4130 / CARBON STEEL</p>	<table border="1"> <tr><td>DRAWN</td><td>DJS</td><td>04/01/2010</td></tr> <tr><td>CHECKED</td><td>LM</td><td>04/05/2010</td></tr> <tr><td>ENG APPR.</td><td>AF</td><td>04/05/2010</td></tr> </table>		DRAWN	DJS	04/01/2010	CHECKED	LM	04/05/2010	ENG APPR.	AF	04/05/2010	TITLE: <h2 style="margin: 0;">MAIN FRAME ASSY</h2>
	DRAWN	DJS	04/01/2010											
	CHECKED	LM	04/05/2010											
ENG APPR.	AF	04/05/2010												
<p>MATL DIM: NA</p>	PROJECT: REVO NAS523 RIVET CODE	BASIC CODE C=CSINK D=DIMPLE FIG-NO. OF SHEETS TO BE DIMPLED	DASH NO FOR DIA. N=MFG HD. NEAR SIDE F=MFG HD. FAR SIDE DASH NO. LENGTH W=SPOTWELD.	SIZE PART NO. <h1 style="margin: 0;">A 100-0100</h1>	REV <h1 style="margin: 0;">A</h1>									
<p>CUT LEN: NA</p>	FINISH: POWDERCOAT	DO NOT SCALE DRAWING		SCALE: 1:24 WEIGHT: 53.79 LBS SHEET 1 OF 6										

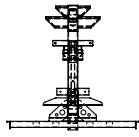
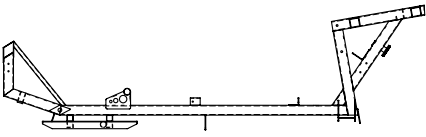
Seat Frame

Type: Heavy Maintenance

Authorization to perform: LSA Repairman Maintenance, A&P, Repair Station

Description: Seat frame on Revo consists of curved T6 aircraft Aluminum tubing that secures into the CNC junction mast block towards the rear and a 4130 bracket on the base tube of the trike towards the front. Damaged seat frames should be replaced by ordering a new one from the manufacturer. Please note the seat frame **IS** a structural component of the main frame.

To replace the seat frame:

1. Remove seat pan.
2. Drill out 4 SS rivets on each side of the mid-section of the body that is attached to the seat frame.
3. Remove the fasteners at the front.
4. Lower the mast and remove the plastic insert to expose the hardware that secures the rear seat frame.
5. Use a rubber mallet to gently slide the seat frame halves out. Note: if the seat frame is damaged, it may take excessive force to slide out.
6. If the seat frame is stuck, remove the lower CNC mast block by removing the 2 through bolts that secure it to the frame.

Welded Brackets

Type: Line Maintenance

Authorization to perform: LSA Repairman Maintenance, A&P, Repair Station, Task Specific – 4130 Steel Welding

Description: There are welded brackets along the base tube of the trike that after welding have been powder coated. If any of these weld are damaged the entire frame must be replaced. See main frame information above.

Engine Mount

Type: Heavy Maintenance

Authorization to perform: LSA Repairman Maintenance, A&P, Repair Station

Description: The engine mount is a solid CNC 6061-T6 aircraft Aluminum and powder coated or anodized. It can be replaced by ordering one from the manufacturer.

To replace:

1. Hoist the engine up until the landing gear shows signs that significant weight has been reduced on the wheels.
2. Remove the 4 mounting bolts in the side of the crank case.
3. Take note of the position of the motor mount so that the engine can be realigned similar when the new engine plate is installed.
4. Remove the 4 motor mount bolts.
5. Slide out the old motor plate.

Ballistic Parachute (optional)

Type: Line Maintenance

Authorization to perform: LSA Repairman Maintenance, LSA Repairman Inspection (only if ELSA), A&P, Repair Station

Description: For maintenance of Ballistic Recovery Chute please follow instructions provided by BRS Aerospace.

Oil Change

Type: Line Maintenance

Authorization to perform: Owner (holds at least a sport pilot certificate), LSA Repairman Inspection (only if ELSA), LSA Repairman Maintenance, A&P, Repair Station

Description: It is important to heat the oil to at least 190°F. In order to do so without overheating the water, especially on the 912iS, the aircraft should be flown or fast taxied. If the Revo is equipped with a Curtis quick drain for the oil reservoir, place a jug under the large black line coming out of the belly and turn the quick drain to empty the hot oil.

If the Revo is not equipped with the Curtis quick drain, loosen the band clamp and the oil reservoir can easily be brought through the rear grill opening. **NOTE: The oil reservoir may be hot.** If you prefer, the entire rear cowling can be removed. Cut the safety wire and remove drain plug and drain the oil.

NOTE

After oil has been drained and or filter has been removed DO NOT turn prop.

Use something below to catch the oil from the oil filter before loosening such as a flexible funnel. Remove oil filter with oil wrench and install new appropriate Rotax filter by lubing the O ring with some new oil (please see Rotax instructions for more detail).

Secure drain plug with new crush washer and safety wire or turn the Curtis quick drain valve to closed, if using one. Add 3 liters of Rotax recommended oil. Turn the prop 10 times by hand in the correct direction with the ignition off. Then crank the engine with the ignition off for 8 sec. Wait for 30 sec and start the engine with the EFIS on and verify minimum 28 psi within 10 sec. If oil pressure does not come up to 28 psi minimum within 10 sec, shut the engine off **immediately** and repeat. If the engine has oil pressure within range run the engine for at least 30 sec and shut off engine and check oil level. If oil is low add oil until the oil level is within range.

CAUTION

Do not fly Revo with rear cowl or rear grill removed unless you are absolutely sure there is no loose objects (small rocks, washers, bolts or nuts) inside the body. Any loose objects generally will fall out during climb out and will most likely strike the prop when the rear grill and cowl are removed.

Brakes

Type: Line Maintenance

Authorization to perform: Owner (holds at least a sport pilot certificate), LSA Repairman Inspection (only if ELSA), LSA Repairman Maintenance, A&P, Repair Station

Description: The Revo uses 3 hydraulic disc brakes that ATF (Automatic transmission fluid or milspec 5606).

WARNING

Using brake fluid in the REVO will destroy the seals and cause the brakes to fail!

The brakes should be checked in every pre-flight inspection for leaks and a solid, hard pedal. The brake pads and the whole brake system and its parts can be ordered from the manufacturer if needed.

To bleed the brakes:

NOTE

This brake system MUST be pressure bled by design.

1. Make sure the brake fluid reservoir is empty.
2. Find a mechanism such as a hand pump oil can or garden pump sprayer and find a soft rubber hose that fits very tightly over the bleed nipple on the caliper.
3. Fill either ATF or 5606 into the pressure mechanism of choice.
4. Slide a ¼ closed wrench over the nipple on the back right caliper.
5. Press the soft rubber hose over the nipple.
6. Unscrew the nipple ¼ turn using the wrench already in place.
7. Start adding fluid to the first caliper.
8. Ensure enough fluid has filled the brake line all the way up to the T which is located at the back of the frame.
9. Repeat steps 4-7 for the left caliper, except this time the fluid must make it all the way up to the reservoir.
10. Fill the front caliper by repeating steps 4-7 and continue to pump until the fluid level is ½ up in the clear master cylinder reservoir.
11. While creating pressure in the brake system, the highest set screw on the front caliper should be backed out until fluid flows from the opening. It will be normal to hear air bubbles escape first. This is the only caliper that must be “burped” since there is an air cavity at the top since the brake line is NOT at the top of this caliper.
12. Confirm the brake pedal is hard when pushed down.

To replace the brake pads:

1. Remove the wheels (See remove wheels section above).
2. With the rotors just sitting in the caliper, twist the rotor gently and open the brake pads up.
3. The rotors are free to be removed by hand. There is just enough space to get it clear of the brake pads.
4. Remove the nonmoving brake pad first, then the piston side.
5. Place the new pads in.
6. Reverse the steps for assembly.

Battery

Type: Line Maintenance

Authorization to perform: Owner (holds at least a sport pilot certificate), LSA Repairman Inspection (only if ELSA), LSA Repairman Maintenance, A&P, Repair Station

Description: Battery is located under the engine at the rear and can be accessed by removing the back lower cowling cover. It is mounted on a steel bracket and is sealed. Only sealed maintenance free batteries should be used in this aircraft or Earth X brand 24D or 36D models. The battery should be kept charged. If storing the aircraft, the terminals of the battery should be disconnected and secured. Changing the battery is a simple matter of disconnecting the terminals, loosening the bracket bolts and sliding the battery out. Reverse these steps to install a new battery. The battery terminals should be kept clean and terminal protecting spray can be used which is available from most auto parts stores.

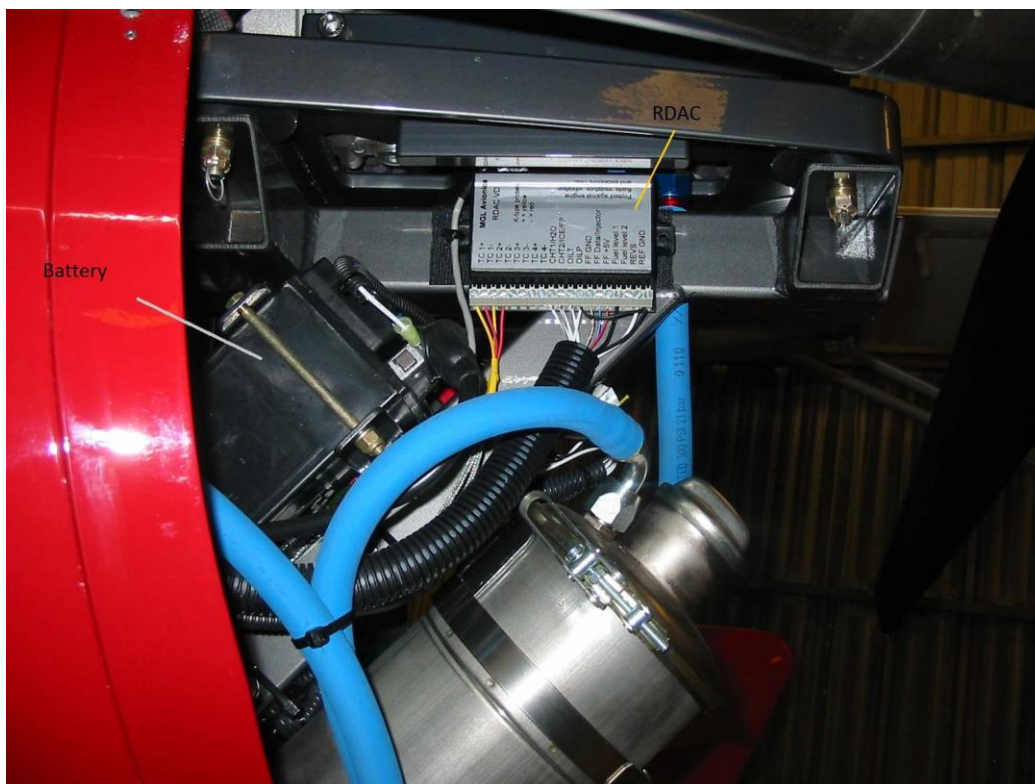

3.2.2.3 Alterations

No alterations to the carriage structure are allowed except those made by the manufacturer and provided as options or for safety directives

3.3.3 Engine

Please refer to the Rotax engine manual for description, maintenance and repair of the engine.

4 FUEL SYSTEM

4.1 General

The fuel tank is a 14.4 US gallon (54 Liters) tank made out of 5051 Aluminum or optional 17.5 gallon tank. It contains a fuel level sender to display the fuel level at the instrument panel. The following diagram shows the fuel system installation. Please note fuel shutoff valve that resides just after the fuel filter and fuel return line that merges into the fuel line with a T-fitting just after the fuel flow sender is not shown.

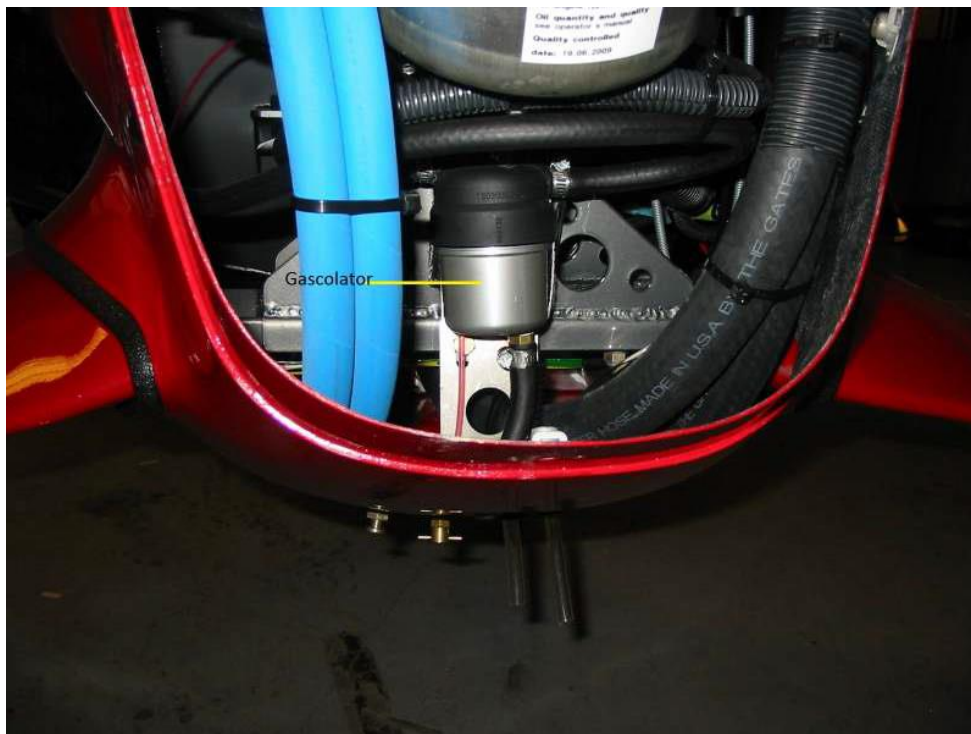
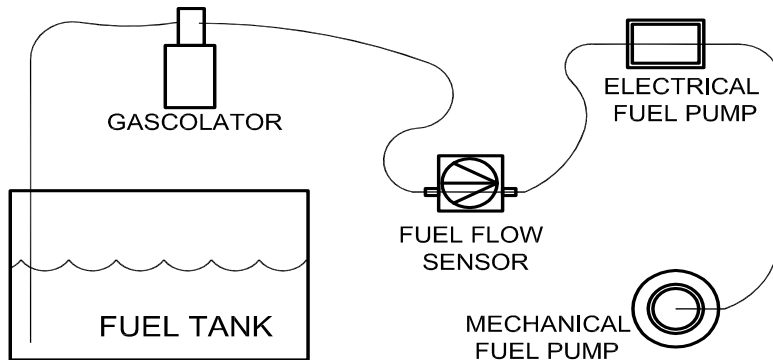

912 iSc/iS

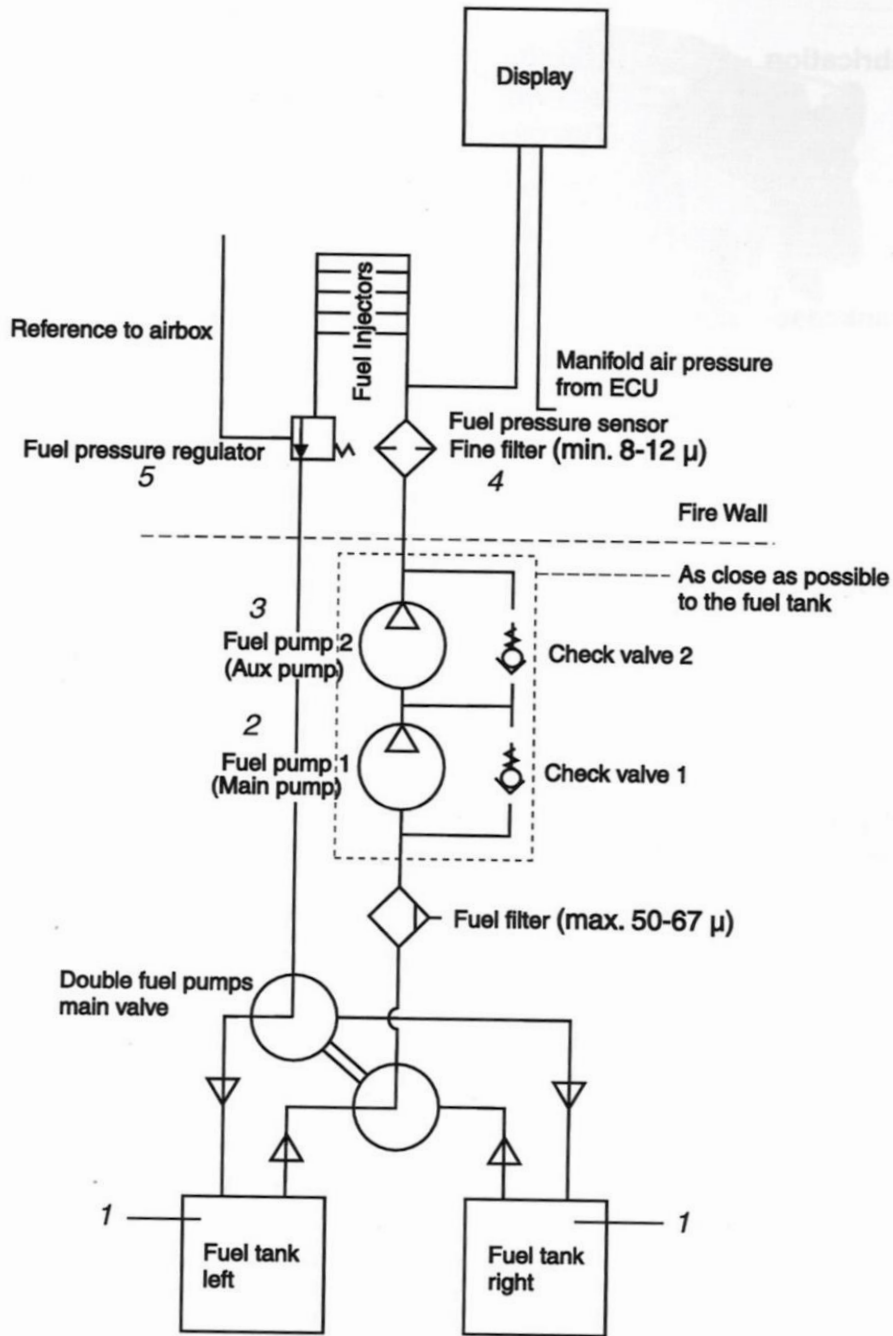

Part	Function
1	Fuel tank
2	Fuel pump 1
3	Fuel pump 2
4	Water trap/fine filter
5	Fuel pressure regulator

4.2 Maintenance

Maintain the fuel system by following the replacement cycle for fuel line, fuel pump (refer to Rotax manual) and fuel filter/gascolator cleaning at annual inspections and perform regular fuel system inspections for safety. Make sure that fuel level sender ground is grounded to the negative of the battery at all times. **This is critical.**

4.3 Alteration

No alteration is allowed for the fuel system except for those authorized later by the manufacturer like replacing a gas tank optionally with a larger gas tank from the factory.

5 PROPELLER

5.1 General

Please refer to the propeller manual for description, maintenance and repair of the propeller

6 INSTRUMENTS AND AVIONICS

These aircraft use MGL brand of instruments supplied by MGL Avionics. A full supplement manual for that instrument is provided. Please refer to that manual.

In addition, a transponder and panel mounted radio installation can be done at the factory or by a factory rep or an avionics licensed A&P in consultation with the factory.

7 ELECTRICAL SYSTEM

7.1 General

The Revo uses a 912 series Rotax engine whose electrical system can be referenced from The Rotax 912 engine manual.

The 912 Trike base has a 12V electrical system essentially comprising of a 12V battery, the Rotax alternator and accessories. The Rotax manual should be consulted for the maintenance of the engines electrical system (Rotax 912 UL, ULS and iS).

An electrical diagram for the aircraft is shown below:

REVO Rotax 912UL & 912ULS Wiring

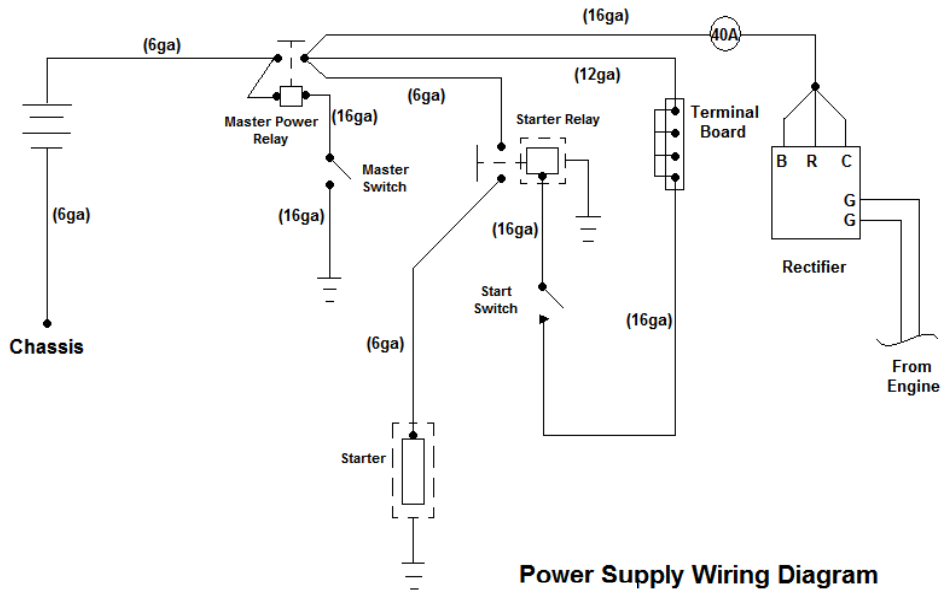

Power Supply Wiring Diagram

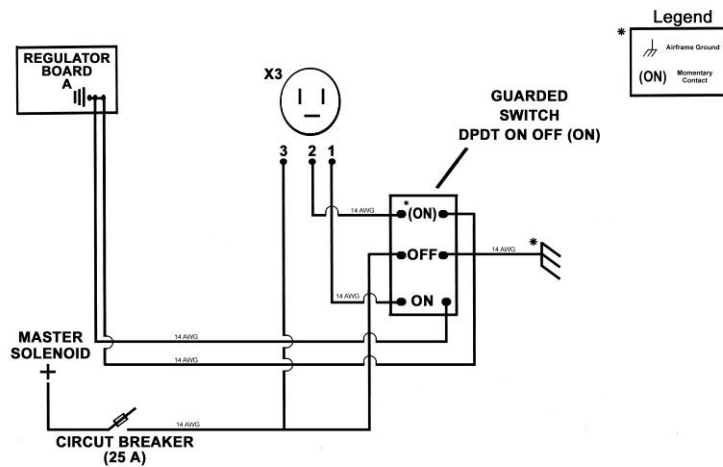

REV. 5/25/2013
REVO ROTAX iS WIRING
 Evolution Aircraft Addendum
 to replace section pertaining to battery
 back up switch and start power switch
 Ref. 24-00-00 pages 24-25
 Rotax 912 i Series Installation Manual

A ground seeking master solenoid has been employed instead of taking power from just the master switch. Power is then fed mainly to a terminal strip under the front of the cockpit from where it is guided to circuit breakers located at the dash which can be reset. A main charging circuit breaker of 25 amps as per Rotax instructions is used in the charging circuit from the engine rectifier.

TEFZEL wiring is used throughout the aircraft wiring harness.

When stopping the engine the ignition key should be put into the off position for 912 UL and ULS. The master switch on the dash should then be turned to the off position (912iS the key is the master switch) and other switches should be turned to the “off” position if applicable.

Below a drawing of how the engine is connected to the RDAC (Remote Data Acquisition Computer) is provided.

Connecting a Rotax 912

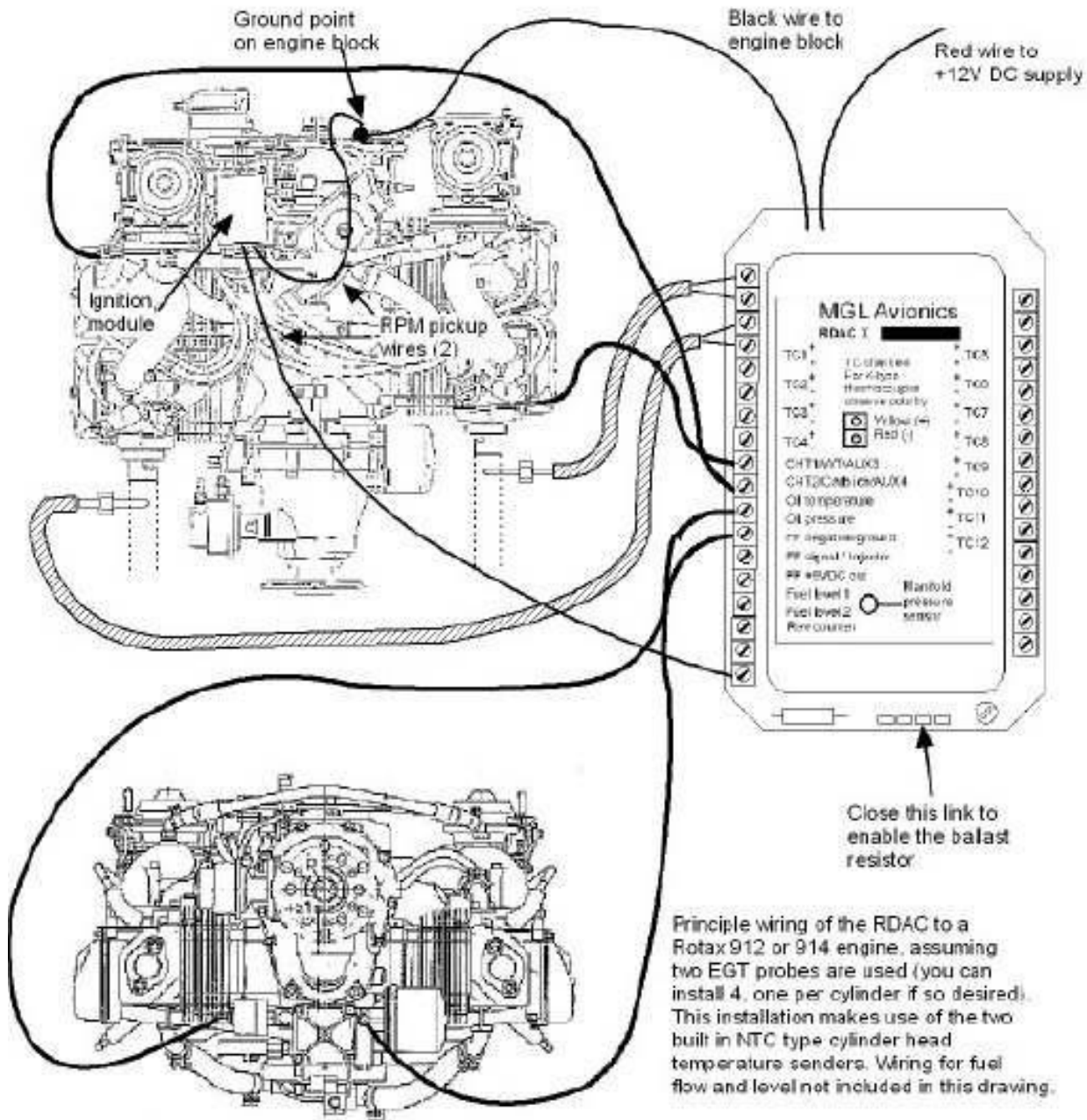

Optionally aircraft can be fitted with a color glass EFIS which has an aviation moving map

GPS built-in. This EFIS is capable of fully programmable multi-screen display.

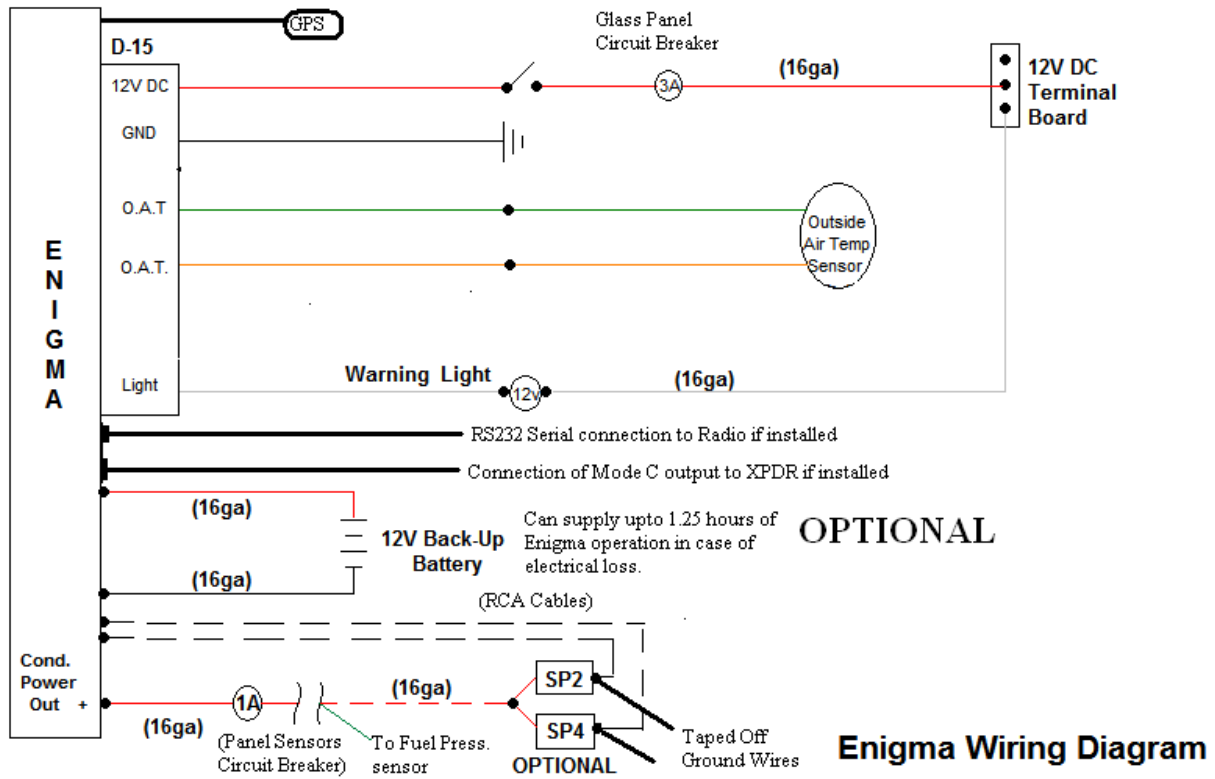

7.2 Maintenance

The maintenance of the electrical system should include periodic inspection of the wiring loom for chafing and other damage through its entire length. Pay special attention to the areas that are subject to possible wear points such as sharp corners or proximity to parts which move. It should be noted that the electrical wires may be subject to wear through vibration in flight. Wiring that is damaged should be replaced and if any wear points are identified then a product such as spiral wrap should be used to cover the area. The advantage with the use of spiral wrap is that it allows inspection of the wires even after it is installed.

Some of the most common ailments are:

1. RDAC 1 failure message on glass panel screen → Check to see that the three data cable wires from RDAC make a solid and good connection to the back of the glass panel. Also make sure that RDAC ref ground is good.
2. Oil Pressure sender reading goes high on glass panel screen → Check to see that oil pressure sender is connected securely to the wire that has a solid unbroken connection to RDAC “OILP” terminal. Also make sure REF. GROUND from RDAC has a good solid and unbroken connection to the engine block however, it is somewhat common to see oil pressure sender failures from normal use.
3. A short circuit → Isolate and investigate.
4. The ENIGMA heading is OFF → Check that if SP-2 Magnetic sensor is connected, it is facing the correct direction (arrow pointing forward). It is possible to move this sensor unknowingly with shoving too much storage under the seats. Re- calibrate the SP-2 sensor (swing the compass on compass rose locally from time to time).

NOTE

New style touch screens do not have this external sensor and self-calibrate in the air.

5. Charging Circuit (Battery) Light does not shut down after engine starts → That means that charging circuit is no longer working and the battery is being drained. Check that the main charging circuit breaker. Also this condition may be caused by Rotax rectifier not being plugged in properly or the rectifier burning out. If so, fix the condition.

7.3 Alteration

No alteration is allowed in the electrical system.

8 STRUCTURAL REPAIR

No structural repair is authorized in the metal structure of the aircraft without consultation with the manufacturer in any part of the aircraft. The parts should be specific and bought from the manufacturer of aircraft carriage or wing as appropriate as long as the manufacturer(s) is able to supply them. Written authorization from the manufacturer is needed if this is to be overridden.

For further information on repairing parts please consult section 3 of this manual. A replacement of parts is the only correct way of fixing fatigued and bent parts. The parts should be original from the manufacture.

9 PAINTING AND COATINGS

9.1 General

The metal frame uses anodization on Aluminum parts and powder coat on steel frame and the engine mount. The Fairing is finished with auto paint and can be re-painted by any qualified auto body shop or an aircraft paint shop. The powder coated parts if found rusted can be cleaned via bead blasting and re-powder coated.

10 MAJOR REPAIRS AND ALTERATIONS

10.1 General

All major repairs or alterations made to aircraft subsequent to its initial design and production acceptance testing to applicable ASTM standards and sale to a consumer must be evaluated relative to the requirements of the applicable ASTM. Contact Evolution Aircraft for an evaluation of damage to maintain SLSA status for any repair or alteration not listed in the maintenance manual or addressed by Safety Directive/Alert or Safety Bulletins.

11 COMMUNICATION FORMS

11.1 Owner Contact Information

It is the Owner's responsibility to provide current Contact information to Evolution Aircraft, Inc. via email at support@evolutiontrikes.com using the format of the following form for the purpose of receiving Safety information and notice of mandatory corrective action.

Owner Contact Information Form

Date Purchased: _____

Name: _____

Business (if applicable): _____

Email: _____

Phone: _____

Address: _____

Aircraft Model: _____

Aircraft N Number: _____

Aircraft Serial Number: _____

Wing Model: _____

Wing Serial Number: _____

Engine Serial Number: _____

11.2 Mandatory Notice Questions or Comments

The owner may submit written comments and questions regarding any mandatory notice to Evolution Aircraft, Inc. by submitting the following form via email at support@evolutiontrikes.com

Mandatory Notice Questions or Comments

Date: _____

Safety Directive #: _____

Name: _____

Business (if applicable): _____

Email: _____

Phone: _____

Address: _____

Aircraft Model: _____

Aircraft N Number: _____

Aircraft Serial Number: _____

Wing Model: _____

Wing Serial Number: _____

Engine Serial Number: _____

Subject:

Description of comment/ concern (attach photos and more pages if applicable):

11.3 Mandatory Compliance with Notice of Corrective Actions

The current owner of this aircraft is responsible to read and comply, as specified within the Notice, with any notices of Corrective Action provided by the manufacturer as well as all applicable consensus standards and CAA regulations in regard to maintaining the airworthiness of the LSA.